

# Innenweltkosmos

## INNER WORLD COSMOS

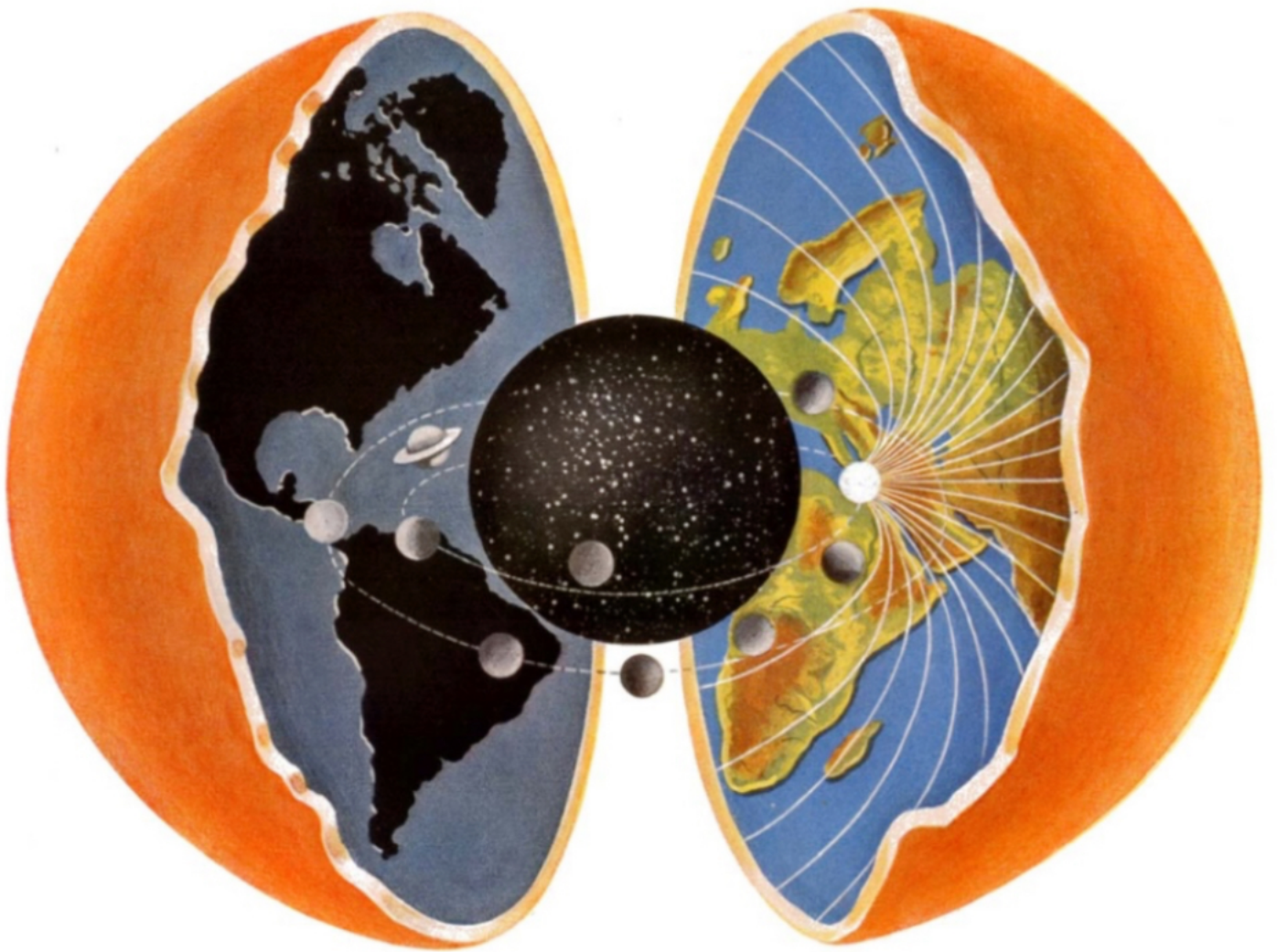

BY HELMUT I. DIEHL (2003)

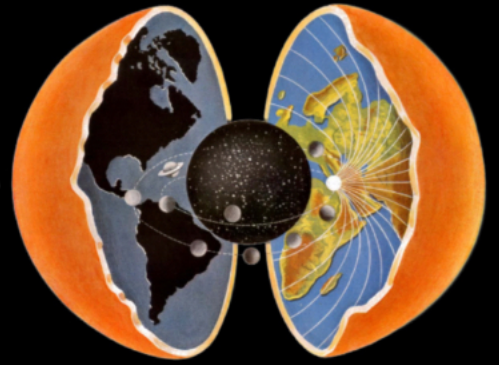
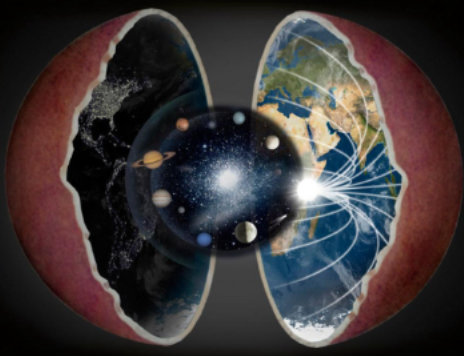

translation by joe dubs

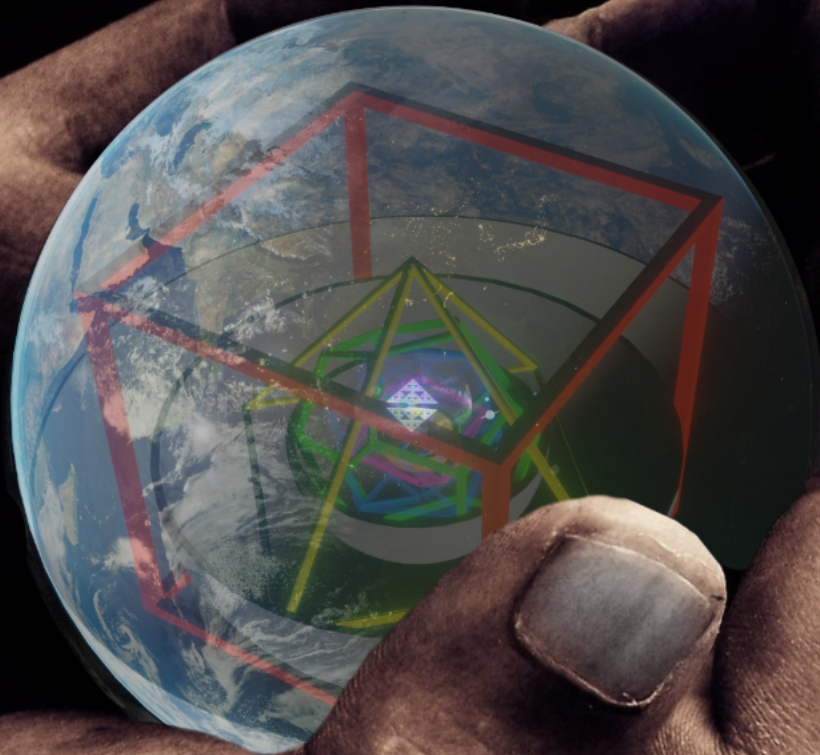

## TABLE OF CONTENTS

FOREWORD .....	4
Dear reader, .....	4
<b>THE HOLISTIC WORLDVIEW – HEAVEN AND EARTH. ....</b>	<b>5</b>
Model and reality .....	8
What was discovered through measurement in 1897 but not taken into account. ....	9
The different worldview models in the history of mankind in their historical sequence. ....	11
Representation of the form, movement and function of the world view models .....	13
Our solar system. ....	23
The Dimensions of the Galactic Universe. ....	24
How can we bring some clarity into the heavenly chaos? .....	24
The end of the scientific age... 28 .....	
The question of the correct worldview..... .....	30
The Modern Conception of the Universe of Astrophysics .....	32
Reality and its mathematical description. ....	32
Does scientific progress without ethical commitment program the decline of human society?... .....	35
Why was the biological model of the cosmos rejected as early as ancient times? .....	36
<b>GEODESY - THE SCIENCE OF THE EXPLORATION OF THE EARTH'S SHAPE 37 .....</b>	<b>37</b>
How can you determine exactly where on Earth you are? .....	40
And how do you measure the angles of triangles? .....	43
Can one measure the curvature of the earth's surface with such a precision theodolite? .....	43
Measurement experiments .....	45
Optical illusions .....	45
Conclusion and Conclusions .....	46
On the problems of geodetic measurement technology. ....	46
Degree measurements as evidence for the concave curvature of the Earth's surface. ....	47
Thoughts on optics... .....	48
The horizon circle as the optical basis of the celestial sphere. ....	48
How is the horizon formed? .....	49
Geometry and the Morrow measurement. ....	50
Professor Sexl and his students at the University of Vienna... .....	51
<b>THE HOLLOW EARTH THEORY. ....</b>	<b>52</b>
The magic of the hollow world (today: inner world cosmos). ....	52
The Dualistic Worldview Model 58 .....	
The Curved Space Metric of the Inner World I. ....	60
The law of inertia..... .....	60
The metric of space .....	62
The etheric sea and its properties. ....	64
Inertia of Matter and Gravity as Effect of the Aetheric Ocean .....	68
Heaviness and gravity... .....	71
This previously described triple identity is the important basis of the inner world theory .....	73
<b>PLANETARY ORBITS .....</b>	<b>80</b>
The planetary system from a Copernican perspective... .....	80
The Curved Space Metric of the Inner World II .....	81
How does the process of planetary movement appear in the inner world system? .....	82
The Bipolarity of the Cosmos According to the Inner World Theory .....	85
Controlling the forces of the cosmos... .....	85
<b>THE LOSS OF REALITY AND THE DIVINE CENTER .....</b>	<b>87</b>
<b>ON THE METHODOLOGY OF THEORETICAL PHYSICS. ....</b>	<b>93</b>
Lecture by Professor Albert Einstein .....	93
The fictitious nature of Newton's system. ....	94

# inner world cosmos

Helmut Diehl

## Preface

My special thanks go to my sponsor, friend and teacher, the cosmologist, mathematician, researcher and writer Johannes Lang (\* 09.06.1899 in Frankfurt/M. Oberrad, d. 23.02.1967 in Offenbach/M) and to all those great scholars to whom I owe my knowledge and progress in independent thinking.

In particular, these are Socrates, to whom I owe the motto of my life: "I know that I (actually) know nothing", so that I remained thirsty for knowledge, the Latin poet Lucretius, \* 55 BC with his didactic poem in which he presents the world view of the Greek philosopher Epicurus\* Samos 341, + Athens 271 BC and the atomism founded by Democritus \* around 460 BC, + around 371. I would also like to thank Prof. Dr. Röth for what I learned from him about the mythology and world views of ancient Egypt.

With great respect I remember Nicolaus Copernicus (1473-1543), Tycho de Brahe (1546-1601), Johannes Kepler (1571- 1630), Galileo Galilei (1564-1642) and the great Isaac Newton (1643, + 1727), English physicist and mathematician. Also Prof. Albert Einstein, \* 1879 in Ulm, + 1955 in Princeton N.Y. USA, for his refreshingly clear statements on problems of theoretical physics, mathematics and the reality of life.

My special thanks go to the two pioneers Dr. Cyrus R. Teed and Professor U.G. Morrow, as well as Professor Roman Sexl, Institute for Theoretical Physics at the University of Vienna. (deceased)

## Dear reader,

This manuscript could only be presented in a scientifically sound manner because I managed to find a professor of physics who mathematically supported the world view of the inner cosmos, the sky-centric astronomical system, and proved it to be irrefutable with the help of the theory of relativity.

The first step to achieving this success was to find a physics student who would examine the world view of "heaven and earth" impartially and use the knowledge he had acquired during his studies.

His first work as a physicist on this topic was a success because a colleague of about the same age, now a professor at the Physics Institute of the University of Vienna, took up this idea of an alternative world view and presented his students with the idea of refuting this system, but this was unsuccessful. In the meantime, the physicist Braun presented his fundamental work "The Inner World Theory", which in its quality is comparable to the great masters of physics and astronomy, because he succeeds in increasing the knowledge of the great masters on a new basis by making great steps forward towards the knowledge of a biological-cosmic reality possible.

It was a great honor and especially a gain for me to be able to help secure the scientific basis for the inner world theory together with two such talented and knowledgeable physicists and to be able to publish it here in a book.

Helmut I. Diehl

# inner world cosmos

## The Holistic Worldview - Heaven and Earth

This book is intended to present the problems of scientific research and imagination in relation to the form, function and the recognizable meaning of the cosmos (universe). It is intended to point out important questions that are still unsolved and, if possible, to answer them from the new perspective and the new findings of the biological understanding of the world.

It is intended to lead to a holistic understanding of the cosmos, as it is presented from the model concept of the mathematical-physical calculation model, which was developed from the Copernican calculation model via Kepler, Galileo and Newton, and on the other hand from the biological model of the cosmos, as it results from the curvature measurements of the earth's surface by Dr. Cyrrus R. Teed and Prof. U. G. Morrow, who demonstrated a concave (hollow-curved) earth's surface and rediscovered the fixed star sphere as a fixed star celestial sphere.

Both models, one represented as a solid sphere with the stars in the infinite outside world and the other as a hollow sphere with the celestial sphere of fixed stars in the middle of the interior, are intimately connected through mathematical transformation and neither can be refuted with the help of mathematics. In this respect, both are absolutely equivalent, as Professor Dr. Roman Sexl, Physics Institute of the University of Vienna, determined together with his students. (See the comments by Prof. Sexl.)

Figure 1 shows the transformation of the straight light rays of the outside world into the curved light rays of the inside world according to the measured angles of the incident rays.

Geodetic measurements using light rays cannot prove either an external or internal world. The human eye can only see the last part of the incident light beam on the retina and the brain, which processes the information, can therefore only interpret the object seen in the direction of the incident light pulse. This is why people as small children have to touch what they see and thereby learn to "understand". This also applies to adults when they see objects in the distance and can never touch them or see them up close; because then they can succumb to optical illusions and a reliable assessment of the distance and size of the object is not possible.

This book is intended to be understandable and yet conscientious; in addition to the popular scientific presentations, scientific advice from experts is also provided.

It is intended to be thought-provoking for the layperson and for the scientist who, outside his or her own narrow field of work, is no better informed than the layperson.

It is not intended to attack science for occasional misinterpretations, but in order to achieve the goal of presenting a true model of the cosmos that corresponds to natural reality, the sobriety of the evaluation of facts, especially measurements, must be the main focus. Where these are ignored, however, a clear language must be spoken in the interest of finding the truth.

There are always psychological barriers to new concepts and ideas, which are often not easy to overcome; because every person first defends his or her system of thought and belief, which he or she has acquired and developed over the course of his or her life and which enables him or her to shape his or her life based on his or her ideas and thoughts. This should not be taken away from anyone, because this spiritual treasure is the source of thought impulses which ultimately become actions.

I would like it to be the case that the reader of this text will be able to gain new perspectives of spiritual vision, which will compensate for previously cherished ideas that need to be corrected, by gaining new, wonderful views, thereby enriching the spiritual view.

At every time in human history, interested people have asked what the world we live in looks like, what shape and size the universe (cosmos or universe) has, how it works, where it comes from or how it was created and, finally, where it leads and what meaning it has. 2003 Helmut I Diehl

All religions, including the Bible, provide answers to these questions for believers in their holy scriptures, often on the first pages.

Since the so-called modern era, however, many people also wanted to know and were not satisfied with just what their worldview of faith told them according to the Bible. Over the last four hundred years, human knowledge in the fields of mathematics, physics, mechanics, etc. has increased steadily, so that a theoretical calculation model of the cosmos was developed that was developed from observation of the cosmos, i.e. natural reality. It obviously describes the cosmos correctly in its quantitative relationships.

A correct quantitative understanding of cosmic reality is one side of what is necessary; a correct qualitative understanding and interpretation of the cosmos is the other, much more difficult side, which is made possible by the biological, cellular hollow sphere model of the cosmos presented here.

Since the biological hollow sphere model leads to the insight that the cosmos is not a machine that came into being by chance, but a biological structure that not only gave rise to life, but must itself be a large living being, as indicated by its form as a large cell, very interesting aspects and questions arise that point to a creator god who is the director and preserver of this cosmos. Anyone who researches and seeks answers to the resulting questions must add to the scientific branches of mathematics, physics, mechanics, optics and logic the scientific branches of biology, morphology, theology and many more; because only with the help of all of science can the great interconnected whole be explained and understood. Only in this way can people be given orientation and an answer to their questions about their origin, continued existence, future, goal and the meaning of life and death; because scientific research and the findings from it, as well as religious tradition and ethics, belong closely together. Anyone who separates the two not only makes orientation more difficult, but also increases the risk of error.

Since human knowledge and experience are constantly increasing and are available to everyone at any time thanks to storage and transmission through modern media, many problems that previously seemed unsolvable due to a lack of information or knowledge are now being solved. Theories that previously seemed incompatible now prove to be just different sides or ways of looking at the same problem.

The purpose of this paper is above all to show that, for example, the mathematical-physical description of the cosmos, as it exists according to the Copernican, heliocentric world model, does not exclude the biological model of the cosmos as a large cell (hollow sphere inner world), or as it was called in ancient times, "world egg" as wrong, but that both models are intimately connected through mathematics through transformation. They are not mutually exclusive opposites, but complement each other as dualistic models of the cosmos and lead to a better understanding of cosmic reality.

While the model of the cosmos is generally known as a mathematical-physical description, albeit not in the sense that it is only a computational model of the cosmos, the important other half of the representation is missing, namely the biological model of the cosmos.

Only a few people are really familiar with the biological description of the cosmos because it is not taught. The educated group of people, to the extent that they even study it, even consider it to be false and disproved. Unfortunately, as Professor Sexl shows, those who think and claim such things lack the specialist knowledge necessary to be able to recognize that this is a regrettable error. It began in those ancient times when people knew too little about the physiology of vision and the optical illusions that result from it. People believed that the horizon and the horizon of the sea could be used as proof that the earth was a solid sphere.

Today, such misconceptions have been disproved by the science of optics, but read more about it in the relevant chapter.

Everyone knows that the visual ability of the human eye has its limits, but what this means for the scientific evaluation of images from the stars and how images of the earth from heights of 200 kilometers or from the moon are to be interpreted is something that the layman cannot know, and a layman here is anyone who is not thoroughly familiar with the scientific branch of optics.

Thus, the sense of sight, as man's most important sense and, as will be shown in the course of the treatise, the system of light propagation, is the reason why man does not have the clear vision he believes he has with the help of his eyes. This is precisely what makes it impossible for man to perceive cosmic reality with his eyes. To do this, he needs all of his senses and, above all, all of his intellectual qualities, such as the ability to judge, intuition, a feeling for the connection of the individual in the whole and love of truth.

Since both worldview models merge into a "dualistic model" of the cosmos through their mathematical relationship, it becomes possible to distinguish and better recognize the mathematical and biological reality of the cosmos.

Through proper transformation, they are woven into one another to form a holistic picture of the cosmos, a model that, in my opinion as editor and that of my co-authors, certainly corresponds better to reality.

This is the important message of this text, in addition to the presentation of the biological model of the cosmos. May this mathematical-biological view of the cosmos be enriching and become a source of new knowledge.

Frankfurt/Main, November 11, 1995 - Estero / Fort Meyers, Florida USA 2001

**Helmut I. Diehl**

## Model and reality

W. Braun, physicist

There have been many worldviews in the history of mankind. A worldview is the product of the effort to satisfy two needs of the inquiring and questioning human spirit:

1. To interpret objective observation facts using concepts taken from the human experience. A world view should explain natural phenomena.
2. To bring the diversity of natural phenomena into an ordering system which allows predictions to be made about the future and the unknown through causal connections.

A worldview is therefore always shaped and determined by the breadth or narrowness of the area of experience and the intellectual horizon of a culture.

The Babylonian world view is rejected today as wrong. However, it was perfectly appropriate for the needs of humanity at that time and should be described as correct in this sense. In this sense, Ptolemy's astronomical system with the earth at the center of an inner world was also correct. It provided excellent services in predicting planetary positions and eclipses. It therefore meets the criteria of modern science.

Why is it then described as wrong today? Our current Copernican-Kepler-Newtonian world view corresponds very well to the needs of the present, including the desire to be able to reach into space. It is therefore generally and completely accepted. No one thinks that this world view could one day be declared wrong because it is not able to answer deeper questions. It is certainly a very useful system that great thinkers of humanity have worked on for many centuries. Its inner coherence is fascinating and it can provide answers to practically every possible question in the causal area of human thought. No one will dispute its practical use in many things either. But it is silent on the really big question about God, the Creator, his throne and his goal for humanity in the cosmos, on questions about the origin of life and what we can recognize as the essence of biology: spirit and soul.

Our current scientific thinking is model-like in nature. A model is a thinking aid for scientists, which makes it possible to answer certain questions and obtain certain statements. If these correspond to the observation of reality, then the model is good and is accepted as useful. The Copernican-Newtonian system of modern astronomy is an excellent calculation model, at least in the area of the heliocentric planetary system, with the help of which very useful and precise research results can be achieved.

But a model, no matter how useful and proven, must never be confused with reality by taking it for reality itself, as is the case today with the Copernicus-Kepler-Newton calculation model.

Unfortunately, this is a serious mistake that Albert Einstein warned against. This fatal error

Unfortunately, it is not only modern astronomy that has fallen

victim to this. However, modern astronomy must be criticized for having gradually forgotten, in the course of its success, to distinguish between the computational model and reality.

It has led to very serious, unforeseeable consequences for all areas of human existence, especially in the scientific, philosophical, religious and thus ethical areas, when the human mind tragically fails here, when it forgets that its thinking is model-based and that reality cannot be thought up but only researched, recognized, revealed and seen.



## What was discovered through measurements in 1897 but not taken into account.

In 1897, Dr. R. Cyrrus Teed and Professor U.G. Morrow measured the curvature of the Earth's surface in Naples, Florida/USA, to determine whether the Earth's surface was completely round (convex) or concave.

This measurement was the first attempt in human history to determine the shape of the Earth.

That the Earth is a sphere was clearly proven by ships sailing around it, but whether this sphere was a solid sphere or a hollow sphere on whose inner surface people live and the Earth is, in a sense, an inner cosmos, had not been investigated for at least the last two thousand years. (The measurement, translated and edited from English by the physicist W. Braun, can be found as an appendix at the end of the book.)

The scientists responsible for the measurements took the visual appearance of the horizon or the horizon of the sea as obvious proof of the Earth's spherical shape. With very few exceptions, this still applies to scientists today, but to their great relief they have found another pseudo-proof: a photograph of the Earth from the moon or from space. Here, too, against better judgment from the optics branch of science, what is seen is uninterpreted and accepted as fact, just as with the horizon and the horizon of the sea, which are only seen. Read about this in the chapter on space flight and photography of the Earth to find out what facts exist and what a correct interpretation looks like.

The measurement by Professor U.G. Morrow, which was carried out on behalf of the Koreshan Unity and its leader Dr. C. R. Teed, took place in public.

The measurement proved that the Earth was a hollow sphere with an inner cosmos. It was published in the book "The Cellular Cosmogony" by the two authors Dr. C. R. Teed and U. G. Morrow and caused a sensation in the press.

Unfortunately, the astronomers were not interested in the facts that had been determined, because measurements on the earth's surface are not part of their field of expertise. Therefore, if they took note of this measurement at all, it was only with disapproval; because what was not allowed to be could not be possible. Those who were neither willing to accept the invitation to take measurements nor had sufficient specialist knowledge of measurement methods criticized this measurement as inaccurate or even impossible.

Doesn't this behavior sound familiar to the reader?

Didn't the famous Italian naturalist Galileo Galilei feel the same way when he invited other scientists to look through a telescope and see for themselves that the planet Jupiter has moons orbiting it, that Venus shows phases like the moon, and that the moon has an uneven surface? Those who denied everything Galileo saw through his self-made telescope refused to look through the telescope. They thought they knew better. The church doctrine of the time did not recognize such "devilish" devices as telescopes, and the scholars did not want to suffer the same fate as Galileo when he supported the astronomical system of Copernicus. Galileo came into conflict with the prevailing church doctrine, which was entirely influenced by the views of the great Greek philosopher Aristotle.

This example shows the refusal to acknowledge facts for psychological reasons, as has happened again and again and continues to happen today. Only when a full professor has given his approval and considers something to be valuable is it taken up and discussed by the disciplined lower ranks. In a certain sense, this behavior is practical and reasonable, but only when it is something fundamentally new can it hold up progress. If something is good and is represented correctly, it will ultimately receive the recognition it deserves, albeit hesitantly. See Galileo's fight for the recognition of his findings and many others after him up to our time.

Morrow's measurement was not recognized by the established scientific representatives and his and Dr. Teed's book "The Cellular Cosmogony" disappeared from libraries without a trace. A librarian who found out about this could not believe it and searched for this book in all libraries in the world and found only one copy of "The Cellular Cosmogony", in which the measurement on the earth's surface was documented, in the Congress Library in

Washington D.C. USA. A second copy, but without the important measurement, was found in

London. This will not surprise anyone who knows the general scientific community. In high science, which is dominated by ideals, there are sometimes, but not infrequently, unfair disputes. After all, there are guardians and ideological, political and religious lobbyists who try to suppress certain ideas, just as is commonplace in the ideological struggle in politics today. It is typically human and why should one be particularly upset about human things? That is just the way it is and one must learn to pursue one's goal persistently despite this. 9

Perhaps the person who does not think independently or who does not research and who has no other option than to trust what he is told, or the expert who is also ignorant outside his field of knowledge, will object at this point that we are generally dependent on trustingly accepting what we learn as correct. Of course, how else could it be, but since life is a learning process and we all have to leave school or even university at some point, we begin to learn from life and there is no professor standing next to us who we can ask for his opinion on whether this or that is true and correct. The necessary decisions are then left to us, and that is a good thing, because otherwise we would just be puppets of those who think for us and thus decide everything for us. So we must learn to ask for facts and learn to evaluate and classify them correctly. Anyone who does not practice this again and again in a learning process will never learn to think independently and creatively. It is necessary from time to time to examine our belief and thought system in order to clear it out occasionally when facts wash away illusions that we have grown fond of. Many readers of this text find themselves in this situation and ask themselves whether they should accept Morrow's measurement and draw the consequences from it and reorganize their belief and thought system, or whether they should evade it with all sorts of lame excuses. Of course, this is up to each individual, as are the consequences. Are there any consequences at all if we remain indifferent or ignore facts? Certainly, because both prevent us from knowing the truth, and anyone who does not seek the truth will not find the reality of existence. They will never grow up and become independent, they will not know what is right, and in times of crisis they will have no answers to solve their life's problems.

When, as here, it is about such fundamental problems as whether the universe is a machine, or not even that, because a machine functions according to the laws of nature and requires technical perfection, but when the universe of space is presented as nothing more than chemical and physical processes that run chaotically in the empty space of infinity and that occasionally gas matter is clumped together into stars by the forces of gravity, only to dissolve again at some point, then those questions arise about the meaning of life, about origin and future and about the goal of it all.

The answers you receive or give yourself determine the meaning of life; because a person acts according to his thoughts. If these are chaotic, his actions are chaotic. If they are orderly and positive, his actions are appropriate and reflect his worldview.

Copernicus' world was obviously still in order. In his astronomical system there was a dominant center. This was the sun, the energy source, which held the solar system together with its gravity, and this inner world was limited by a shell of fixed stars. A god could still live behind this star sphere.

Only when this starry sphere was pushed further and further away and finally dissolved into a void of space with highly diluted gases, in chemical processes of creation and decay, was there no longer any room for God. Now there was no "up" and "down". The creator God was no longer needed to explain the universe. God was simply abolished in the French Revolution, which is called the Great, and reason was elevated to God's throne. The consequences are well known from history. The beheading of the ruling authorities began, and mutual distrust followed by the murder of fellow human beings.

The Copernican idyll of a closed inner world is a thing of the past and no longer exists, even if it is still alive in the minds of many people, fortunately for them. What is today presented as the universe on the basis of astrophysics causes a hopeless atomization and isolation of man; because what is formed inside a person through his thoughts is considered by man to be true and consistent with reality, so that it forms models for his actions.

If many people have the same guiding principles based on the same worldview, the so-called zeitgeist emerges. As we know from experience, this determines the thoughts and actions of the majority of people.

That is why the correct knowledge of what is real is so important; because the recognized truth or the false interpretation of reality becomes our fate. That is why it is so important that we must make a serious effort to recognize reality and interpret it correctly. Misinterpretations lead to ideologies and misunderstandings, then to enmity, and these lead to civil wars or wars with neighboring countries. In both cases, this destroys culture and means death for many people. But a cultural revolution with the decline of ethical values that were generally binding in the Christian West is also a disaster. What will become of the young people who today, in the year 2001, experience how the ethical minimum behavior of man, summarized in the Ten Commandments, is disregarded? Is the cause in the cultural revolution that began in 1968, which was triggered spiritually by the fact that the successes of space travel obviously made a deep impression on humanity?

The first Russian astronaut Gagarin said proudly and arrogantly on television to the world public: "I was up there, there is no heaven." He meant heaven as God's "throne." No one contradicted him; he was a hero who was forgiven because he was the first person to reach a height of around 200 kilometers in a rocket.

Today, space stations are being built at altitudes of 200 to 500 kilometers.

In contrast, the landing of the US astronauts on the moon was a real sensation that changed the way many people think, because until then the moon had been a celestial body. The raising of the American flag on the surface of the moon was tantamount to taking possession of this companion of the earth, which had previously been called a celestial body. The average citizen, the "little man", was thus unsettled in his faith in God and, in the course of the many moon landings, lost what Christians call the fear of God. But where there is no longer any fear of God, ethical norms are no longer observed. They decay with the false knowledge that there is no God and where there is no longer any heaven.

The call for the preservation or renewal of Christian ethics is futile under such conditions, because what is there to renew? A lost faith, which was lost because the Christian world view of faith was destroyed, can only be restored if those destructive influences are recognized and people are given the correct picture of God's cosmos that corresponds to reality.

As will be shown, the correct model of the cosmos that corresponds to the facts and measurements is the dualistic world view, formed from the calculation model that was developed from the Copernican system and the model that shows the biological reality of a hollow spherical shell of the earth with the celestial sphere in the center and the planets including the sun and moon, which orbit the main body, the sky or celestial bodies on their special orbits. As the mathematical evaluations of the orbits of these celestial bodies show, this model is in correct agreement with the measurement data. (See the explanations "Astrometry in the sky-centric world model")

The entirety of this dualistic worldview shows people the reality that they have lost, namely the celestial body at the center of the cosmos, the celestial firmament, the divine center that has been lost for centuries.

If God is recognized again, all errors will collapse and a renewal of Christianity will be possible if God is spiritually seen again, up high and in the middle. In this middle there will no longer be the symbolic seat of the power-obsessed Antichrist, who sat on God's throne for over two thousand years, as was thought to be the case according to Ptolemy's world model. There is also no sun in the middle of the cosmos or a spiral nebula billions of light years away, however imagined. These speculations have been refuted by Morrow's measurements and other evidence and facts presented in this document. Of course, many people will find it difficult to check and correct cherished ideas, but if the facts force them to do so, many will succeed, especially the ordinary person who had given up his world view of faith due to the misinterpretation of space travel because he received no help from the responsible party in his distress of faith. Namely from the scientists or those in charge who work for the churches. They will most likely not recognize the dualistic worldview as the model of the cosmos presented on the first page of the Bible. They failed Galileo Galilei and should be a little wiser this time and search for the truth themselves and research the Scriptures to see if this is indeed the case.

Nothing else can be expected from the enemies of God and the enemies of the serving church except rejection.

## The different worldview models in the history of mankind in their historical sequence

All worldview models that have been developed throughout human history show a basic pattern:

The basic shape of an egg. A shell defines an enclosed interior space in which is located what, together with the shell or boundary, is called the cosmos or universe. The world view gets its name from the structure that is at the center of this cosmos or universe. For example, geocentric world view (ge, Greek = earth), because the earth is at the center. or heliocentric world view (helio, Greek sun), because the sun is at the center. In the oldest world view, handed down to us by the ancient Egyptians and the Bible, the celestial sphere, also called the celestial firmament, is at the center. In German, this world view would be called the sky-centric world view. Since heaven is called Uranos in Greek, this world view could also be called the uranocentric world view. However, this term is taken up by the name of the planet Uranus. So we chose the term "Celestro Centric System" for the English language.

The world view represented today by astrophysics probably has its center in our galaxy. This could be called the "galaxicentric model"

It is very interesting that the oldest traditional world view states that the center is in the sky, while the most modern, the galaxy-centric world view, assumes that its center is somewhere in the stars, and therefore also believes that it has found it in the sky. Of course, both ideas mean something different by a center, but they have nevertheless arrived at the same place. Is this just a coincidence or a logical consequence that developed intuitively?

In addition to the four basic models mentioned here, there are two more world views that must be mentioned because of their importance: The world is represented as a disk, surrounded by the ocean and covered by the firmament. There may certainly have been many people who, based on the view of the earth's surface extending to the horizon, were faced with such a

Fig. 2.1-4

world view, but not the astronomers in Babylon. They achieved extraordinary precision and would have been very aware that their trigonometric structure, horizon circle, meridian and optical vault of the sky was a mathematical framework with the help of which the observations and exact measurements of the celestial bodies were possible. They did it in the same way that we still do today when measuring with a precision clock, when the daily circle of a celestial body is measured in time and degrees of arc, minutes of arc and seconds of arc. It is not justified to describe this mathematical structure as a Babylonian world model, but arose from the same lack of understanding and ignorance as the model of the cosmos, which is clearly but briefly described in the Bible, is misinterpreted today. Anyone who does not know the basic model in Figure 11 will have a hard time interpreting it correctly.

The Danish astronomer Tycho de Brahe was a diligent and successful observer of the sun, moon and planets, whose observations Kepler, who learned from him, was able to use for his theoretical representations. He rejected the heliocentric world view of Copernicus and stuck to the geocentric world view, but changed the system of planetary orbits. (See Figure 2.3)

Finally, we should mention the world view of faith. It is also called the theocentric world view because, according to this idea, God's throne is located high up in the innermost part, in the center of the world. This world view of faith, identical to Fig. 1.1, was the general spiritual belief of Christians up until space travel. Since 1968, many Christians have abandoned this world view of faith. They, the believers and theologians, had long been confused by the heliocentric world view model in their belief in heaven as the seat of God's throne and abandoned this belief when the statement of the first Russian astronaut was published in the world press: "I was up there, there is no heaven." This flight was certainly a pioneering achievement, but Gagarin had only survived one manned rocket launch into the upper gas layers of the earth at a height of 50 to possibly 100 km with a safe landing. When the US NASA carried out its moon landings and allowed the public to participate through television by showing pictures of the moon and an optically small earth in the distance, Copernicus's world view model, which had previously been considered a mathematical model, finally seemed to be proven.

The optical phenomena were not scientifically investigated, but people believed what they saw and wanted to believe that there was no heaven and no God.

Only a few believers were not so quick to deny God. They appealed to the Bible and the words of Jesus Christ. They suspected or knew that what man sees with his eyes requires interpretation, especially scientific interpretation. But the scientists of optics and mathematics neglected to do this and left people, intoxicated by technological successes, with their false belief that what man sees, no matter how far away, is an image of reality.

The official church representatives, their theologians and experts remained silent because it seemed to be the wisest thing to do given their level of knowledge. Once again they allowed the image of heaven and earth handed down or revealed in the Bible to be "knocked out of their hands".

The image of the cosmos based on the statements of the Bible is identical to the ancient Egyptian, sky-centric world view model.

Representation of the basic models

1.The celestial-centric worldview (celestial English heaven(s)) (heaven in the center)

The Worldview of Faith or Theocentric World Model (identical to 1)

2.The Geocentric Worldview, (geo from Greek ge earth) (earth in the center)

3. The world view of Tyche Brahe. (geocentric)

4. The Heliocentric Worldview (helio, from Greek sun) (sun in the center)

5.The Galaxiocentric Worldview (from Greek Gala Milk, Galaxy Milky Way. (Center of the universe in the Milky Way) 2003 Helmut I

According to this worldview, our solar system belongs to the Milky Way star system.

6. The world view model as a disk or the Babylonian world view.

## Representation of the form, movement and function of the world view models

### 1. The Celestro Centric System

In the celestrocentric world view, the celestial sphere is in the middle. It rotates around the 360 degrees of the earth's orbit in 1436.068 327 640 769 minutes, while the earth's shell, which closes and encloses the space, stands immobile or is firmly established. The interior of this earth body (inner world cosmos), or large cell organism, is permeated by a subtle substance called ether. It washes around everything like a sea and penetrates everything we know. This is why the total mass of the ether was also called the ether sea. Since the subtle substance ether was officially abolished in science due to the Michelson Morley experiment, but the celestrocentric world model cannot do without this subtle substance to explain many phenomena, it was reintroduced as the ether sea. This etheric sea, structured as a force field, rotates 360° once around its axis in 1436.0 minutes

This rotation is called orbital driving motion and causes the daily cycles of the planets, day and night, the years and also the other orbital periods. See the necessary explanations under the title "The primordial force field".

On the earth's surface lies the air (atmosphere) and above it are the highly diluted gases.

The circulating driving force field acting in this inner world not only fills the interior with its vibrations, but also penetrates the earth's shell, which is at least 50 to 100 km thick, and continues to act on its outer surface and in the outer space according to the energy that has penetrated.

Gravity, a property of mass and presumably of the orbital driving force field, must also have an external effect. Experiments on the moon, which in the sky-centric world view is a hollow body with content like all planets and the sun, have shown this.

From practical experience we know nothing about the space outside the Earth's shell.

Of course, one can think about whether there are perhaps other hollow shells of the earth floating or lying outside in space. How many, infinitely many or few, large or small and how big is this external space? If it is infinitely large, then the number of structures similar to the earth can also be infinite, and so on and so forth.

You can think like this as much as you like, but to what limit? Is there a limit at all? You can quickly imagine and fantasize about something that you cannot know anything about and build an illusionary world in your mind.

This is exactly the way one philosophizes with insubstantial mathematics. One imagines a point without extension and an infinite extension of the universe. What is supposed to come out of this nothingness? Certainly no organic creature, heaven and earth, can come out of it. What is needed is what one calls a creator, who organizes, sets dimensions, assigns qualities, gives meaning and content.

The moon, at an estimated altitude of about 3000 km, is closest to the Earth's surface. That is why its orbit is the longest. It is estimated to have a diameter of about 200 km. Although it would have been possible to determine these dimensions during the lunar flights using the mileage counter on the lunar rover, the simple mechanical device that could have measured the distances was unfortunately not trusted and was declared defective during the lunar flights. But perhaps the exact values will be known at some point. What we can learn from NASA today does not match what the astronauts said during the lunar trips. (Read: The lunar flight in the inner world, practical experiences on the moon.)

In the sky-centric world model, the sun is also a planet. Its size can only be estimated and could be about the same as that of the moon. The sun is thought to be at an altitude of 4000 km. Measurements using the light beam, which is curved in the sky-centric world model, are not possible because the curvature of light and the speed of light have not yet been determined experimentally. Experiments in this regard have not yet been carried out because light bends to different degrees and travels through space at different speeds depending on the density of space. See the latest experiments on the speed of light and the propagation of light.

Until now, the scientists have been content with the speed of light measured at the earth's surface of 300,000 km per second and the assumption that the light beam is mathematically straight if it is not deflected. Many deflections are known, but for reasons internal to the system we must stick to the axiom that light is straight, otherwise, according to the director of the Bochum Observatory, Mr. Herrmann, the world model of the heliocentric system would collapse like a house of cards.

This is logical and understandable, because just as the heliocentric system includes the straight light beam and the constant speed of light, the system of the sky-centric world view includes the light beam with varying degrees of curvature and the varying speed of light. Both depend on the density of the space. If this is not homogeneous, light cannot propagate in a straight line, but is curved.

The etheric sea (formerly called ether or sometimes called electron sea) that fills space and permeates everything is the carrier of all electromagnetic vibrations. Due to its structure and movements, the etheric sea (electron sea) causes different densities in space and this in turn causes, according to the laws according to which a condensation occurs, the light propagation shown in the sky-centric astronomical system, similar to the electromagnetic field.

Whether the term electron sea or ether sea can be retained will be decided in the future; because research in this area of particle physics is in full swing and when reliable results are available and can be correctly interpreted, it may become necessary to create new terms.

The planets float, so to speak, in the etheric sea (sea of electrons), which is excited by the electromagnetic vibrations and condensed to different degrees.

The etheric sea (sea of electrons), it is assumed, is designed similarly to an electro-magnetic force field, rotating once every 1436 minutes around its axis, which is inclined by 23 1/2 degrees to the north-south axis of the earth's shell. This force field not only causes the orbital propulsion movement, but also phenomena such as light, heat, magnetism and the orbital movement of all celestial bodies, including the moon and the celestial sphere.

The order of the celestial bodies in the inner cosmos shows the moon as the closest celestial body to the earth and therefore it has to travel the longest or largest orbit. The astrometric measurement data of the moon thus become an indication of the accuracy for the inner world cosmos. (See Astrometry in the Inner World) The next celestial body is the sun, which is orbited by the planets Mercury and Venus. Mercury orbits the sun on a smaller orbit and is therefore closer to the sun than Venus.

Then follow on their orbits the planets Mars, Jupiter, Saturn, Uranus, Neptune and Pluto, which has the smallest orbit to traverse.

What is depicted as a fixed star sphere in the models outlined under 1.2 to 1.4 is here in the sky-centric world model the fixed star celestial sphere, i.e. the rediscovered sky as the largest celestial body. All planets, the sun and the moon orbit around it. This fixed star celestial body is not fixed, but rotates around its axis in 1436.068 327 640 769 minutes and thus around the 360 degrees of the earth's orbit, which has no movement of its own and is firmly established.

The size of the celestial sphere cannot be measured or calculated geometrically, as previous calculations have shown. The results obtained are too small and, when compared with the biological models of nature, cannot be correct. The reason for this is the assumption of exact circles for the path of light rays in the interior of the cosmos. If one tries to use morphology (the study of shapes) to determine the diameter of the celestial sphere, the sun and the moon (because it has not been possible to calculate this until now), it could be correct to assume that the fixed star celestial body has a diameter of around 1000 kilometers. In contrast, a diameter of around 200 km is conceivable for the sun and the moon. There are mathematicians so clever that these can be determined to acceptable sizes using real data obtained from the journeys of the lunar rover.

In 2002, a debate arose about these vehicles. Did this moon car really exist? Where was it taken? It was not visible on the lunar module. Were the film recordings of the lunar rover or rover vehicles that were published at the time taken during exercises in the desert? NASA should withdraw falsely declared images or films that were made public in any way and were recognized as fakes, because one cannot yet seriously claim that the moon flights did not take place. Unfortunately, this dilemma is further exacerbated by the fact that no information was given about the distances traveled during the first trip with the moon rover because the mileage or odometer was supposedly defective. On the other hand, no one can demand that NASA publishes everything it has discovered at great human and financial sacrifice.

Finally, the astronauts were not allowed to say anything in public about what they had seen or experienced without the express permission of NASA, under threat of punishment. Read the report on the 2003 flights by Helmut I Diehl 14

to the moon with the eavesdropping of the astronauts' conversations.

The diameter of the celestial sphere of 1000 km, i.e. 10th of the diameter of the earth, is perhaps correct because it fits with the forms of nature in terms of size and proportion.

A cosmos created in a cellular structure, consisting of the large cell of the hollow earth sphere with the hollow celestial sphere, shows identical characteristics in comparison with the biological cell; because this world model is a biological model and consequently it is to be expected that all bodies, sun, moon and planets, are large cells in this biocosmos.

The propagation of light, the creation of day and night, the seasons, the phases of the moon and eclipses are reported in the relevant chapter. This is about presenting the basics of the models.

Summary: The Earth's body consists of a hollow shell that encloses cosmic space and is about 50,100 km thick. Nobody knows what is outside. The core of this large cell forms the celestial sphere. This rotates on its axis and is orbited by the planets, the sun and the moon.

What is particularly striking is that the moon has the largest orbit and the sun the second largest. In addition to the main effect of the celestial sphere of fixed stars, both celestial bodies have special functions.

The moon, with its proximity to the earth and its assumed height above the earth's surface of about 3000 km, is related to the earth. Together with the sun, it causes the tides and the high and low pressure eddies of the air masses. Both the sun and the moon together shape the climate (seasons) and the weather. The effect of the moon on living beings and their rhythm of life has been sufficiently proven by natural scientists.

The sun, with its proximity to the planets and the celestial sphere, has an extremely important function due to its position and function in the so-called zodiac, which is a concentration of energy in the electro-magnetic force field. The sun is the converter of this energy, which appears primarily as heat and light.

This sky-centric worldview is the oldest tradition in the history of mankind. It was not only taught in ancient Chinese and Hindu culture, but also in ancient Egypt, Greece, and among the Nordic peoples, as well as among the indigenous peoples whose worldviews were never mathematical or technical, but were primarily based on biology.

Regarding the evidence:

There are proofs, indications from all branches of science, logical and philosophical, theological and, above all, comparative observation of nature, especially biology, so that, like a mosaic picture, truth and Reality of this world view is assured. In addition, theoretical physics with its mathematical reasoning, after the transformation from the external world to the internal world, becomes harmonious with the sky-centric world model to form a holistic world model.

Join us, the authors of the following presentations, in experiencing the adventure of how seemingly contradictory ways of thinking come together to form a holistic view of the cosmos.

But let us now turn to the second model of the cosmos, developed by ancient Greek philosophers and passed down to us by the scholar **Claudius Ptolemy**.

## 2. The Geocentric World Model or the Ptolemaic World View

The geocentric world model also has the basic shape of an egg or a cell. A hollow sphere with stars that are firmly bound to one place on the inner surface, i.e. this sphere of fixed stars, encloses this hollow sphere, in the center of which the globe rests motionless.

The sphere of fixed stars, including the moon, the sun and the planets, rotates around this firmly founded earth according to the measured daily circles. A daily circle means the observer's orbit of 360 degrees. It is measured in hours, minutes and seconds. The daily circle of the sun around the earth is given as exactly 1440 minutes. The time that the sun needs to complete the 360 degrees of the daily circle is set as a basic unit of 24 hours. The sun needs 4 minutes for each degree of the circle. 360 degrees times 4 minutes = 1440 minutes.

According to this geocentric world model, the moon is the next celestial body to orbit the stationary earth in an exact circle on its orbit, which is the smallest. This is followed in their circular orbits by Mercury, Venus, the sun, Mars, Jupiter, Saturn and finally the sphere of fixed stars.

This Geocentric worldview was the misunderstood and modified successor model of the Skycentric worldview.

As will be shown later and is now clearly established after the Egyptian hieroglyphs have been deciphered, the sky-centric world view was retained in Egypt for religious purposes and practical life, but a mathematical model was needed to calculate the positions of the sun, moon and planets. This mathematical model of the geocentric world view served well for over two thousand years, until it finally no longer met the high demands for accuracy. It failed in particular because people did not want to give up the exact circular orbits of the sun, moon and planets, even though they recognized that this could no longer explain the temporary retrograde motion of the planets in a simple and logical way and they wanted to hold on to the idea that the celestial bodies were attached to transparent crystal spheres.

As a result of the irregularity in its orbit, Mercury describes loops on the celestial sphere. But all the other planets also describe similar, smaller or larger loops on the celestial sphere and sometimes even appear to stand still. Today we know that these are optical phenomena.

Mercury and Venus never move beyond a certain distance from the sun. The so-called upper planets Mars, Jupiter and Saturn do not exhibit this peculiarity. They can move up to 180 degrees away from the sun.

Generations of ancient scientists tried to solve all these problems mathematically. The geographer, astronomer and mathematician Claudius Ptolemy, a Greek who lived in Alexandria (Egypt) in the 2nd century, was particularly successful in this regard.

Ptolemy tried to solve all these inequalities in the orbits of the planets with the help of the epicyclic theory. Ptolemy's world view thus became a purely geometrical structure and therefore probably survived all crises and the decline of the famous School of Alexandria, which fell into disrepair as a result of political and religious turmoil.

Finally, the question remains: What was beyond the height of the sphere of fixed stars? There was the heaven of the believers and the throne of God. There was no longer a divine center here. The center occupied the earth with man. For God, only the height and the infinity of the outer space remained.

What consequences did this view of the world have for religious, philosophical and scientific ideas?

For philosophers and scientists, this meant the loss of the divine center. The living space of man was thereby considerably expanded (in the imagination): and God was, so to speak, "put out the door." He was now outside, still up high, but somewhere, and since he had once set his world in motion and it was going its own way, God was only needed occasionally as a stopgap. So a representative of God was needed on earth.

They were god-kings or so-called sons of God who were endowed with divine honors and were supposedly appointed by God as his representatives. This tradition continued into our time, in which the royal dignities that still exist are established by the grace of God, rather than by popular election and will. This is especially true of Christ's representative, the Pope of the Catholic Church. He sat on the throne of God in the middle of the world, which, according to the ideas of the time, belonged to man and whose arbitrary will could cause terrible things, or whose goodness could sometimes be a blessing.

But it was not only those in power who took themselves so seriously; normal people also became arrogant. They began to "believe" in themselves, experimenting with the forces of nature, plants and animals, and with people themselves, as if everything belonged to them. They took everything apart as if it were an object and thus began to destroy the basis of their existence. First spiritually, by practicing a false religion and introducing a false understanding of the world through philosophy. Later, when thinking became actions, the physical destruction of the basis of life for people and animals also began; for people had been declared masters of nature. God and his angels still hovered high up in heaven, but far enough away that people believed they would only be accountable to him after death.

The rule of the powerful, the church and the nobility allied with it, became so oppressive that nothing could move spiritually any more. Everything seemed to be at a standstill.

Copernicus' new world view burst into this situation like a bomb.

It was perceived by the oppressed as a great opportunity to free themselves from ecclesiastical and secular tutelage.

Because now, according to the new world view, the rulers no longer sat on the fixed throne of God in the middle of the world on the resting earth, but the earth itself now rotated around itself like a carousel and was thrown in a gigantic orbit around the sun. After fierce arguments with Galileo Galilei, who was supported by Johannes Kepler



supported, the heliocentric model of the world slowly gained influence, but the most important astronomer of the time, Tycho de Brahe, rejected Copernicus' heliocentric model.

### 3. The Geocentric Astronomical Special Model of the Astronomer Tycho de Brahe

Brahe's special insights

However, Brahe did not abandon the geocentric view that the Earth is the center of the planetary system. In this Tychonic system, the Sun and Moon are also satellites of the Earth.

The moon orbits the earth. The planets Mercury, Venus, Mars, Jupiter and Saturn do not orbit the earth, but the sun. The sun in turn carries the system of planets with it as it orbits the earth. The planets therefore perform a compound movement: 1) they orbit the sun and 2) with the sun around the earth. This is how the planetary loops come about. The planets actually move through these loops and are not just optical phenomena like in the Copernican system, because what the observer sees in the celestial sphere cannot be recognized in its spatial arrangement and leads to misinterpretations. Johannes Kepler struggled with this optical problem when he was asked to investigate the orbit of the planet Mars for his employer Tycho de Brahe, because human spatial vision without technical support ends at a distance of around 100 m. Did Kepler know that the image seen on the celestial sphere does not reveal anything in three dimensions? Optical glasses in the form of a primitive telescope had just been invented and Galileo invited Kepler to look at the sky with his replica binoculars. But Kepler could not accept this invitation. He was probably just as inexperienced in this respect as many stargazers today who imagine that they can see in three dimensions, but this is not possible due to the distances. (See the treatise on vision and on the optical appearance of the celestial sphere.)

In his time, Tyche de Brahe discovered that Mercury and Venus orbit the Sun and that the Sun orbits the Earth, which is consistent with the celestial-centric world view that was unknown to him, but not with the heliocentric system that was just becoming established at the time. This is the reason why this successful Danish astronomer is often forgotten, although Kepler owes most of his astronomical observation data to Tycho de Brahe.

#### The Heliocentric World Model or the Copernican World View,

The heliocentric world model, as presented by Copernicus, also has the basic shape of a so-called world egg or cell.

A hollow sphere, on whose inner surface the stars are fixed, encloses the interior of the hollow sphere as a fixed star sphere. The fixed star sphere is at rest; it does not rotate or move.

At the center of this inner space of the world is the resting sun. The planets and the earth move around the sun in precise circular orbits.

In this world model, the moon is a companion of the earth.

As clearly as this model is presented here, it was not that easy for Copernicus. He had to break away from the teachings of the venerable Greek philosopher Aristotle, which meant a great risk for him, because Aristotle's philosophical teachings were identical to the teachings of the Catholic Church in many statements of faith. This was certainly one reason why Copernicus hesitated for so long to make his work public. Legend has it that on the day of his death, Copernicus got his hands on his work "De Revolutionibus Orbium coelestium Libri VI" on his deathbed in 1542 and blessed it.

He was worried about many unexpected problems and feared the misunderstandings of those who would not understand him and would not realize that he represented the world mathematically with the help of geometry.

He had to critically examine the two previously inviolable axioms of the great Greek philosopher Aristotle, which no one had doubted for over 1000 years because they were considered to be obviously true by all scholars, and immediately abandon one of them, namely that the earth is at the centre of the universe. He provisionally accepted the second axiom, that the planets in heavenly space could only be assigned a perfectly harmonious circle as a planetary orbit. He therefore had to explain the unequal speed of the earth on its circular orbit around the sun, like Ptolemy had done earlier, by assuming an eccentric circle. But where the eccentric circle was not sufficient to explain the unequal speed of the planets on their orbits, he had to use an epicycle as an aid. In the case of the moon, he was even forced to use an epi-epicycle.

Despite the problems that arose and were only solved by Copernicus' successor, the brilliant astronomer and mathematician Johannes Kepler, who introduced the orbital ellipse, Copernicus, by establishing the heliocentric world view system, gave the human mind a completely new, wonderfully simple and symmetrical 18

mathematical model is presented, which has been developed over the centuries into an admirable calculation model by many ingenious scientists.

Copernicus himself said: "By no other arrangement have I been able to find such a wonderful symmetry of the universe and such a harmonious connection of the orbits as by placing the sun, the world's luminary, as the ruler of the whole family of orbiting stars, in the middle of the high temple of nature, as it were on a royal throne. Who could possibly find a better place for the sun in all of nature than that from which it can illuminate the whole."

Every new observation, every new discovery was at the same time a confirmation of the correct mathematical function of the system, but not of the truth itself; for truth and mathematics have nothing to do with each other in the sense that mathematics could prove human or divine truths.

Today, in 2001, there is still no evidence for the heliocentric astronomical system in the form of exact measurements. What is offered is a well-developed calculation model of a high quality never seen before in human history.

That is why he probably wrote the sentence at the beginning of his main work: "No entry for non-geometrics", which can only mean that the astronomical system he revised was a mathematical system and was only intended for the better calculation of the sun, moon and planetary tables, but not for philosophical and religious speculations, which later came to pass.

Up to this point in the representation of the heliocentric astronomical system, the mathematical transformation of the heliocentric system into the sky-centric astronomical system is possible. Facts and theoretical representations are still based on scientific thinking, logical conclusions and life experiences gained through observations. What follows, however, goes against the wisdom of the great Greek philosopher Aristotle (384 BC to 322). He taught to act and think according to the following principles and logic: First investigate the perceptions, once they are sufficiently known, they are to be trusted more than speculations, and only when they agree with the experiences and principles of nature.

Copernicus soon abandoned this path of scientific procedure in order to overcome difficulties.

Copernicus was unable to provide any real evidence for the correctness of the heliocentric system. He based his assumption that the earth rotates around its axis within 24 hours on a series of probabilistic conclusions. A number of serious objections can be raised against his assumption that the earth orbits the sun.

For example, the main objection that the fixed stars do not show an annual parallax. This objection was rejected by Copernicus' assumption that the fixed stars were infinitely far from the earth and therefore no measurable parallax could be determined. This theoretically made the earth a point and the sphere of fixed stars an infinity.

The reception that Copernicus' astronomical system initially received was very cool, if not exactly unfriendly. But that changed when ideologists declared the Copernican astronomical system to be the absolute truth, thereby shaking the foundations of the Christian faith. From then on, for the first time in the foreseeable past, there was an astronomical world view in which there was no longer any heaven, no above and no below; in short, there was no longer any place for God, ideologically speaking. He could no longer be found and, after a short period of mechanistic explanations of the phenomena, was obviously no longer necessary.

The world, which had previously been a creature of God (a living being) in the imagination of men, now became a world machine with a sun in the center of the world that radiated heat and light by burning fossil fuels.

With this, the tragedy of the loss of the divine center began to fully unfold.

First in theoretical science, then in philosophy and finally in faith.

But what was beyond the sphere of fixed stars in the heliocentric world model? At first, the pious believed that they would find God in the heights. But when the sphere of fixed stars was completely abandoned and an infinite space of the unlimited expanse of the universe was taught, it was no longer philosophically conceivable to speak of a heaven as a place and a God in the emptiness of space.

The heliocentric world model had lost its limiting sphere of fixed stars and the sun was no longer at the center of the world. Everything had dissolved into speed and into the immense expanse of infinite space.

What consequences did this have for people's religiosity, philosophy and thinking and actions?

Had God, the creator of the cosmos already been banished from the centre of the cosmos in the geocentric world view model, with

Despite all the devastating consequences, even though he could still be outside the celestial sphere, this development towards distance from God was intensified to the point where the idea of God was completely eradicated; for where there is no heaven, there is no God. Around a hundred years after Copernicus' death, God was officially abolished during the French Revolution and reason was established as the highest authority of humanity. This was made easier by the fact that philosophy and science separated at the end of the 16th century. Modern science began to live its own life, separated from God.

The church was still teaching the worldview of faith where it was allowed to operate, and Christians who practiced their faith were not yet affected by the consequences of spiritual events. But among the intelligentsia of the people and those who had fallen away from the church, a change began towards human self-determination, towards liberation from the guardianship of the church authorities.

The moral decline had devastating consequences. Christianity split and some believers, including Luther, accused the Pope of sitting on the throne of God as the Antichrist.

The peasants demanded exemption from the heavy taxes paid to the clergy or the feudal lords. Their protest and revolt were bloodily suppressed. This eventually led to the Thirty Years' War (1618-48) with the terrible atrocities committed against Christians of both denominations.

The old order dissolved and the exploitation of nature, animals and people began. As the losses from the destruction meant there was a lack of capital, the moneylenders had their moment of glory and lent money at high interest rates because of the great risk. Hated by the people, but needed by the princes as a means of raising money, the age of capitalism began. Money began to rule the world, with customs and morals taking second place. Marx and Engels opposed the ideology of capitalism with the ideology of the dictatorship of the proletariat under the term Marxism. Together with the socialists and humanists, this formed the International, the religion of the modern age, under the leadership of the communists. Its aim was to establish the human kingdom, a paradise on earth without God.

The consequences of these ideologies, whatever they were called (including the ideologies that fought against communism, fascism and National Socialism), with their dictatorial, centralistic, inhumane claim to power, led to economic decline, murder, war and expulsion instead of prosperity for the people and the state. The peoples who had abandoned God, their creator and sustainer, now became victims of God's adversaries. They appropriated the state as a form of organization for a people and began their reign of terror over the people. Despite everything, business flourished because everything could be sold or exploited without restraint. There were hardly any moral barriers because the earth and the entire universe belonged to the people; they themselves had conquered it by having thought it up.

A humanity grew up that had abandoned God and now reached for the stars. First for the moon; because that is where the conquerors' flag stands, which according to old custom means that this land (the moon) belongs to this state. The "great deed" of man emancipated by God was the seizure of the moon and the utilization of the space above the earth's surface up to a height of over 500 kilometers, because this is where the rockets to the moon and the planets are launched from.

Where will this lead?

## The modern world view of theoretical physics and mathematics as space with stars

### A further development of the Copernican, Kepler, Newtonian calculation methods

The main objection raised against the heliocentric system was that the fixed stars in the background of the sky did not show an annual parallax. In astronomy, parallax is understood in the narrow sense as the angle between two straight lines (lines of sight) directed from different observation points to a celestial body, i.e. the angle at which the base appears from the celestial body.

This objection was about the annual parallax. The basis for this was the orbit of the Earth around the Sun. It must be remembered that Copernicus initially used the traditional basic form of the world: an inner space was enclosed by the sphere of fixed stars and the Sun was in the center of this space. The Earth orbited around the Sun in a circular orbit. When the Earth orbited around the Sun, the stars should have shifted purely optically in the background of the sky; because, it was argued, when the Earth moves in its orbit around the Sun, it approaches certain fixed stars and then moves away from them again. Therefore, these fixed stars should show a similar apparent movement in the background of the sky as the planets, namely parallax shifts in their positions.

Copernicus replied that the fixed stars were infinitely far away.

In doing so, Copernicus initiated something whose consequences he probably feared. He eliminated the structure that was called heaven in his time, the place or space in the heights where God had his throne according to the beliefs of believers. The rejection of the Copernican model of the world with the sun in the middle and no sky by the priests and believers of the Christian church was thus inevitable.

Thus, in people's minds, an idea arose of the universe of unlimited infinity, of the Earth rotating on its axis, in which a person living on the equator is swung around at a speed of over 1600 kilometers per hour, at the same time as the Earth on its orbit around the sun reaches a speed of around 107,000 km/h, and in addition races with the sun towards the star Vega at 70,000 km/h. An idea of a universe of rapid movement and infinite expansion arose.

Was this conception of the world the reality that was discovered? Or was it merely a new model experiment based on mathematics and speculation? What facts were there that confirmed this picture of the world?

Here we must again refer to the brilliant natural scientist Galileo Galilei, who began scientific theoretical thinking with his experiments and findings. These were particularly his experiments with free fall. His most mature work, the *Discorsi*, his textbook for theoretical physics, was published in 1638.

Undoubtedly, this worldview was built on the basis of observation of nature and backed up by the means of mathematics, so that any intelligent person had no objection to it as long as the facts that had led to this worldview were mentioned.

But these were only assumptions, for example that the earth must be a sphere based on the surface we see, and a solid sphere at that.

Since this was obvious from the convex surface of the earth seen with one's own eyes, this assumption was considered proven. It was considered an axiom that the light ray is identical to a mathematical straight line. According to general opinion, an axiom does not require proof because it is obviously not necessary. The fact that the sun had to be at the center of the heliocentric world model could not be disputed either, along with the claim that the earth moves in a large orbit around the sun; because this representation belonged to the heliocentric system of this world view.

The English mathematician and physicist Isaac Newton made the greatest progress in the field of general theoretical physics and celestial mechanics with his celestial mechanics. He developed the laws of falling and the theory of gravitation from measurements and observations of free fall. Newton's findings also apply to the four world views presented above and only need to be kept free of assumptions about the straight beam of light and the full spherical shape of the earth; because the distances, sizes and masses calculated on the basis of these additional assumptions are theory that only relates to the heliocentric world view and are not facts, even if they are presented that way by ignorant people.

What was still missing as proof was an actual measurement, and this was provided, it was believed at the time, by the German astronomer Bessel, who had first measured the distance of a star in 1838.

**How reliable was this measurement?**

Well, he had acted exactly according to the rules agreed upon by astronomers. He assumed that the light ray and a mathematical straight line were identical and calculated the distance using trigonometry and the actual measured parallax.

What was an exact measurement here? Only the radius of the Earth, which was calculated based on degree measurements and the calculation of the Earth's circumference. And then what else? The angle of parallax was measured. It is the angle formed by straight rays of light from the star with the radius of the Earth.

The assumption used for this calculation based on the radius of the Earth was the unproven assumption that a light beam is straight over a distance of a million times the distance of the sun from the Earth (150 million kilometers). Furthermore, that the Earth must be a full sphere, which is not proven by anything and is only an assumption based on optical phenomena.

What is called measurement here is a calculation based on several assumptions and has only a theoretical value.

This theoretically determined value was then used with further assumptions and theories as follows:

The star apparently measured by Bessel in this way appeared to be a relatively close neighbor of the Sun because it was only a million times as far away from the Earth as the Sun.

The first important step that astronomers took was the theoretical realization that our sun, as hot and large as it is, appears to be just one of many suns in space. The second important step was that astronomers began to "measure" all the nearby stars using this theory.

The limits of this theoretical method of measurement with trigonometry were refined by theoretical assumptions, so that soon theoretical distances thirty times greater than those of the first theoretical star measurement were determined.

For even greater distances, certain conditions must be met before the distance to a star can be estimated; this is nothing more than an estimate based on certain assumptions. In plain language, the case is as follows: For so-called "close" distances, the direct method of estimation is used: For "medium" distances, there is a second method which, when used for close distances, probably produces the same results as the first method, and is therefore assumed to produce results of the same accuracy up to the limits of its usefulness. It is based on the assumption that a certain type of star, the behavior of which has been observed precisely in representatives that are somewhat close to the Earth, behaves in the same way even when the great distance makes control impossible.

Finally, for "large" distances, a third method is used, which, however, entails a certain reduction in the possible assumed accuracy.

For the greatest astronomical distances, one can therefore only give approximate distances, which presuppose the validity of certain assumptions. However, there is no way to prove whether these are correct. It remains a guess.

When you hear or read that this or that structure, which has just been discovered with one of the most powerful telescopes in the world, is so and so far away from the Earth, there may be a two in front of a fabulous number of zeros. This may not be quite right, perhaps a 1.8 or 2.2 may be more correct, but the number of zeros is probably pure fantasy.

To get a rough idea of the diameter of the star system in which our sun is located, we would have to multiply the sum calculated above (150 million times one million) by 45. This system includes not only the five thousand individual stars that we can see with the naked eye, but also the billions of faintly shining stars, some of which form the clouds of the Milky Way.

The term cosmos is no longer suitable for this conception of the universe; it fits the three inner worlds depicted in the skycentric, geocentric and heliocentric world models.

That is why new terms have been used here. The star system to which our sun belongs is our universe. Beyond our universe lie millions of other universes, each of which probably contains thousands of millions of stars. All of them together make up the universe.

The shape of our star system, i.e. our universe, was recognized as that of a disk, similar to a discus with a center, a north pole and a south pole.

Isn't it surprising that the new model of the universe and all other universes in space are supposed to be disk-shaped?

With the newly calculated distances in space (as of around 1950), we are no longer able to imagine distances with numerical values, so the following picture from 1950 is to help:

If we imagine our star system with its thousand million stars, i.e. our universe, compressed into the size of a penny or a cent, the nearest universe is about two penny diameters away by this scale. The most distant universe calculated so far from these two universes is about six hundred penny diameters away, and this universe is also a member of a group of universes that are close to us.

Since the year 2000, the above assumptions about sizes and distances have long been outdated, because everything has expanded at an incredible speed.

Anyone who wants to imagine an impressive model of thought using theoretical physics of space on so-called educational trails near Bremen or Marburg will learn the following:

## Our solar system

### size and mass

The diameter of the sun is 1,392,530 km (that's 109 Earths side by side, and more than 1 million Earths fit into it). Its mass is 330,000 times that of the Earth, making up 99.9% of the mass of the entire solar system. The remaining 0.1% is distributed among all the planets, including the satellites.

Nevertheless, the sun, as a "yellow dwarf", is only a medium-sized star in cosmic terms, although the moon with its orbit around the Earth would have enough space in half the size of the sun. In its core, 464 million tons of hydrogen fuse every second to form 460 million tons of helium. The energy created is squandered in all directions of space, 380 trillion kilowatts per hour. In the process, it loses around 346 billion tons of mass every day, but because it has a large mass, it only decreases by 0.03% of its mass over five billion years.

### Energy and temperature

The surface temperature is around 5,700 degrees C, and the core is much warmer: 15 million degrees C. Our Earth absorbs only 2 billionths of the total solar energy. Every second, the sun generates more energy than man has created since the beginning of time.

If you were to take a piece the size of a pinhead from the center of the sun and place it on the earth, it would kill people 150 km away from the heat. Every second, the sun produces as much energy as 400 billion power plants on earth.

### life

Our sun is estimated to be around 4.5 billion years old. This means that it has lived half its life. It begins to swell at the age of 7 billion years, as the pressure inside it has become greater than the gravity exerted on the sun from the outside. It soon reaches twice its size and the earth's climate changes. In northern Europe, temperatures reach 40 degrees C in winter. After another three billion years, it has become a death star, a "red giant" that has absorbed and destroyed all the nearby planets (Mercury and Venus). The main star of the constellation Taurus, Aldebaran, is currently in such a stage. It is visible in winter.

### Distances

The distance between the sun and the earth is 8.3 light minutes, which is 1 astronomical unit (AU) 149,565,800 km. If you were to fly at the speed of sound, it would take 14 1/2 years to get from the sun to the earth. It rotates on its axis once every 25 days. Although the sun is 400 times bigger than our moon, it appears to us to be the same size in the celestial sphere. This is because it also happens to be about 400 times further away from the earth than our satellite.

These data and assumptions result from calculations based on the following previously formulated assumptions:

1. Light travels in a straight line and has a constant speed of 300,000 kilometers per second.
2. The Earth is a full sphere, rotates on its axis in 24 hours and orbits the Sun in 365 days on its orbit at a distance of 149,565,800 kilometers from the Sun. It forms a center of gravity for its planets and moves at great speed towards the constellation Hercules in the northern sky.

## The Dimensions of the Galactic Universe

How can you get an idea of the dimensions?

To get an idea of the enormous distances in the cosmos, here are some visual aids:

1. If you say a number every second, you can count to 1,000 in about a quarter of an hour. Under the same conditions, assuming an 8-hour workday, it would take a month to count to 1 million. In about 80 to 120 years, depending on the length of the workday, you might get to 1 billion.

In the following text, the term light year is used to indicate distance. What is a light year? A distance that light travels in one year, assuming that light travels 300,000 km/sec. (three hundred thousand kilometers per second) in one second. How many seconds are there in a year? A year has around 365.242 days, 24 hours is 8765.808 hours. An hour has 60 minutes, a minute 60 seconds (60 times 60 = 3600 seconds). So 8765.808 hours of the year times 3600 seconds = 31,556,908.8 seconds in a year. Since light travels 300,000 km per second, 31,556,908.8 seconds must be multiplied by 300,000 km. This results in a distance of 9,467,072,640,000 km (i.e. almost 9.5 trillion. In Germany, a trillion is a million times a million)

Translated into cosmic terms, this means: Our galaxy (Greek galaxos = milk), commonly called the "Milky Way", consists of around 100 billion stars (suns), it measures around 110,000 light years in diameter, and around 16,000 light years thick in the center. Our solar system is around 28,000 light years from the center. The total mass of the Milky Way is 1.4 trillion solar masses. How many planets the individual suns = stars of our Milky Way have is still completely unclear. Likewise, whether and in what way life in any form exists on them. Assuming we could see all the stars in our Milky Way, it would take us 8,000 years to count them all.

2. If we walk along the planetary educational trail at an average walking speed of 4 km/h, this corresponds to a cosmic speed of about one million km/sec., i.e. we are speeding through our solar system at more than three times the speed of light, because light travels a distance of 300,000 km in one second (distance between the moon and the earth = about 1.2 light seconds).

3. Or to put it another way: Light orbits our Earth about 7 1/2 times in a single second.

4. If we want to take a look at the nearest fixed star outside our solar system from the planetary trail, we must be prepared for a long journey. The nearest fixed star (Alpha/Proxima Centauri) would be 40,000 km away in our model, scaled down by 1:1 billion, but actually about 4.3 light years, i.e. we would have to orbit the earth once. We would have to go around our globe twice if we wanted to see the star Sirius in the constellation "Great Dog" (the brightest fixed star in the northern hemisphere, visible in winter). It is actually about 9 light years away from us.

5. Please note: Both are stars in our Milky Way, our closest neighbors.

How can we bring some clarity into the heavenly chaos?

All the stars, planets and moons that can be seen in the night sky belong to our Milky Way, only the "Andromeda Nebula" in the constellation "Andromeda" is a different galaxy. It is about 2 million light years away and can be seen with the naked eye as a blurred spot of light on clear autumn or early winter nights. The Andromeda Nebula is racing towards our Milky Way at a speed of 1112 million km/hour, but because of the enormous distances from us, there will be no "collision" in the foreseeable future.

There are about 100 billion Milky Ways of this type in the universe, and it is estimated to be about 1520 billion years old.

When astrophysicists were able to reliably estimate other universes, they made a surprising new discovery: they found that some universes are moving toward us and some are fleeing from us at an incredible speed of 40,000 km per second.

Calculations, not measurements of such speeds, are of course based on inferences and not on



Time measurements with the clock.

The attentive reader will not have failed to notice that this Galaxiocentric Universe is an astrophysical model developed from the elements of mathematics and from assumptions of the creative imagination.

This model of the universe flatters the human mind, because with the imagined size of the universe, people believe they are growing spiritually. They are flattered to have invented such sizes and they probably also believe they can comprehend everything. So this serves the self-glorification of people and that pleases them.

But the other models of the cosmos also showed the greatness of the human spirit, but here in the glorification of the Creator.

In the Galaxiocentric worldview model, however, man has conceived his own space monument using the means of theoretical astrophysics.

He is obviously capable of both: rising high and falling low.

This is the tragic greatness of the human spirit.

The above representations of the model of the Galaxiocentric Universe are partly taken from the book by A. W. Haslett, "Ungelöste Probleme der Wissenschaft", Verlag Otto Lorenz, Vienna-Leipzig 1935, title of the English edition: Unsolved Problems of Science, and from the Lexicon of Astronomy, Spektrum, Akademischer Verlag Heidelberg-Berlin-Oxford 1989.

Also recommended is the book by Frank J. Tipler, USA, mathematician and cosmologist: The physics of immortality. Modern cosmology, God and the resurrection of the dead. R. Piper GmbH & CO.KG, Munich 1994.

It shows the spiritual consequences of materialistic thinking without the Creator God, thought through to its logical conclusion.

The following presentations and thoughts are a brief summary of what the mathematician and cosmologist Tipler thinks about the shape of the universe, its origin and future. For the sake of curiosity, Tipler's ideas follow.

When Tipler received his PhD, his specialty was global general relativity. This sub-discipline of physics allows mathematical speculation and very general conclusions about the structure of space and time.

Tipler regrets that most cosmologists are concerned with the visible universe, the part of the universe whose past can be seen from Earth. (The light is only just getting here for us to see its past now; it is that far away.) Since the universe is thought to have been formed about twenty billion years ago, and since nothing travels faster than light, if these assumptions were correct we could see the past of galaxies that are now about 20 billion light years away. This means that we are seeing today what happened twenty billion years ago. What happened there in the meantime we do not know.

The visible universe is a spherical space in which we find ourselves, which has a diameter of twenty billion light years. It is obvious to everyone that the visible universe only captures a tiny fraction of reality.

The universe will almost certainly exist for another hundred billion years, but probably much longer. In other words, the part of space-time that we can see from Earth is relatively insignificant compared to that which lies in the future. The origin of man therefore falls in the very earliest childhood of the universe. Therefore, Tipler is concerned with the future, because this future contains almost all of space and time. Otherwise it is impossible to see the universe in its entirety in time and space.

But how can we calculate the behavior of the universe in the future? It is assumed that the processes will be chaotic. This makes the development of the universe unpredictable because we now know that development is chaotic on all astronomical scales. This includes the solar system, galaxies, galaxy clusters and even the entire universe.

Tipler, as a mathematician and cosmologist, believes that humans, as intelligent beings, are quite capable of exploiting these instabilities by manipulating them.

In other words, if one wants to calculate the future of the universe, one cannot ignore the possible activities of intelligent life in any calculation of the development of the distant future. This makes calculating the future seem completely impossible, because human behavior is known to be unpredictable. This chaos would be added to the chaos in Einstein's equations.

Tipler now comes to a conclusion, which cannot be proven by anything, that the chaos of the universe and the chaos added by intelligent beings would cancel each other out. This would happen as follows: In order to survive, intelligent life must use the chaos in the laws of physics to force the evolution of the universe into a very limited number of possible "futures." Its very survival requires it to impose order on the universe, and only the inclusion of biology allows us to have a physics of the distant future.

The most interesting thing about Tipler's mathematical thought process is that he adds biology to mathematics, which is completely new.

Until now, the universe was at best a primitive machine in the imagination of scientists, which was described with the help of mathematics and thus developed into a computational model that explained events and allowed predictions.

Editor's note: In the presentation of the holistic world view "Heaven and Earth", the decisive new thing is that the previously missing shape science of biology, i.e. the living, is added to the proven calculation model of the cosmos.

So here too we have a biological addition, a new reference to the reality of the natural.

Tipler then presents a description that is rather sobering. Tipler writes that for him a human being is nothing more than a special kind of machine, and the human brain is merely a device for processing information. The human soul is programmed by the brain like a computer.

Tipler writes that many people not only think this view of life is wrong, but find it downright repulsive.

He argues that if humans want to survive in the long term, they will eventually have to leave the Earth and colonize space; the Earth is doomed because the sun's luminosity increases with each passing day and in about seven billion years the sun's outer sphere will have expanded to the point where it will swallow the Earth. That would be the end of humans and all life on Earth.

In order to bring life to eternal life in the universe, Tipler proposes the conquest of space by man, who must, however, be transformed first.

He assumes that in the future it will be possible to build intelligent machines that are human beings, and he has the vision that one day people will be able to create computer machines that are so intelligent that they can absorb all the information needed to biologically recreate a human being using the resources available in distant galaxies.

This brings us full circle: Man has spiritually created a universe with an infinite number of universes and is transporting his production data via intelligent machines to distant galaxies for organic resurrection and eternal life. If it were so, or if it were to be so, then man would be like God and could create himself for eternal life.

A utopia, a delusion, a desperate attempt to save life from chaos? Here, scientific thinking with the help of mathematics became a religion of salvation according to the formula "chaos plus chaos = new order".

When writing down these thoughts, one is reminded that great ideological projects act precisely according to this evil: they try to change a social and economic chaos by trying to change the chaos using other chaotic means (strikes, slander, lockouts, etc.). So far, this has only resulted in greater disorder and the loss of the few remaining forms of order.

The philosopher, Professor Günther Zehm of the University of Jena, had the following thoughts about this wonderful new world in his essay, "The New Clarity", dated February 2, 2001:

"If you listen carefully when serious people are talking, you will hear a new tone. Everything is getting more difficult, it is agreed in these circles, the time of simple problem solving is over. Behind every hill we climb, mountains rise up that we had no idea existed. The further we go, the longer the path stretches.

The natural sciences have now had to admit their failure. Their hope, inspired by physics as the leading science for centuries, that they could solve the world's mysteries with the help of a few elegant formulas and even establish a snappy "world formula" in the end, has also proven to be an illusion.

The new leading science, namely biology, the science of life, is firmly opposed to all equations and formulas. The research area that biology opens up no longer resembles a geometric baroque garden, but is a wild, overgrown alluvial forest criss-crossed by countless rivulets. Behind every bend in the river, completely new, completely unexpected perspectives open up, and anyone who wants to mark off the area would only destroy it.

The "decoding of the human genome" last year (or rather the comments that were linked to it) was such a circular attempt. It failed spectacularly. It quickly became apparent that the lock into which the supposed key was inserted was much more complicated than some had believed.

There is reasonable suspicion that what has happened to natural science will also happen to all other fields of science.

Biology is the science of life, and life is, under all circumstances, a highly fragile and transient state. Any action under its sign is like open-heart surgery, whether it takes place in the laboratory or elsewhere.

Biology is not physics, living nature is not mere particle matter whose movement can be calculated down to the last decimal point. Infinity is no longer just a mathematical function that one operates with like plus and minus, but a constant, concrete awareness of the inexhaustibility of the research object and the arsenal of methods.

It is possible that in the future such awareness will be regarded as the main characteristic of any responsible researcher or actor."

So much for Professor Zehm.

What exactly is it about? The life of all living creatures has become a source of danger that is difficult to ignore due to theoretical physics and enormously successful mathematics in conjunction with technology.

It started out seemingly harmlessly with the invention of the steam engine, whose soot only polluted the air. Then came the petrol and diesel engines, which not only polluted the air but also changed the air we breathe. They used up the oxygen for combustion and left behind air that was useless for all living things because it made us sick or led to fatal poisoning. Why did we survive anyway? Because there was still enough good air without toxins, provided by the natural order of nature.

The machines lubricated and operated with oil had another dangerous side effect: technical oils and fuels such as petrol and diesel consist of hydrocarbons. If these get into the ground, they contaminate the water and make it undrinkable. Countless small springs have already been contaminated by hydrocarbons and can no longer be used as food. Now we buy bottled drinking water and this food, like air, which was given to people and animals as a gift by nature, is now as expensive as the fuel made from oil for the internal combustion piston engines.

The entire rise in the technological age of the "modern era" would not have been possible without the engine and the materials for combustion, i.e. the energy sources. Natural scientists searched for and found the energy sources needed in the modern era in coal and petroleum.

Many wars have been fought because of these substances stored in the earth and countless people have been destroyed as a result.

In order to use even more energy, physicists and chemists found a completely new source of energy in radioactively decaying elements, especially uranium, and built the atomic bomb to end and avoid wars, as is so optimistically presented.

Used against people in Japan, these energies caused unprecedented destruction of material nature and had a terrible effect on biological beings such as humans.

This primordial fire completely destroyed mankind. All that remained of mankind was a little soot in the form of radioactive dust. Those who were not fatally hit fell ill, and pregnant women in the early stages of their child's development were hit so hard that terrible deformities arose, which were shown to no one out of horror. The formative genetic fine energies had been thrown into disarray.

After this first terrible attempt by the military, an opportunity for the peaceful use of nuclear energy emerged.

What should also have been frightening, but preferred not to be, was the associated possible radioactive contamination of all materials and thus of all living beings that are made up of these basic substances (the chemical elements).

It was supposed to be one of the cleanest and cheapest forms of energy. But it became the most expensive and dangerous, because the radioactive substances that were safely stored underground, encased in pitchblende, were extracted and processed. Some of the dust that was created got into the air we breathe and the groundwater. This meant that the toxins were in the food chain of all living things. How great is the health damage to current living things and their descendants? Who of those responsible is seriously interested in this? Only the environmental and life conservationists raised their voices.

What to do with the toxic radioactive waste? This problem is unsolved. The next generation will pay for it.

The greatest evil of our mechanistically successful science and time is the intrusion into the interior of the cell structure and the already repeatedly successful attempts to genetically modify plants, animals and probably soon also humans.

It always starts with great utopias about how we can improve the health of living beings and their food or how we could help the sick.

## The End of the Scientific Age

Under this title, Prof. Dr. Herbert Pietschmann, Professor of theoretical physics at the University of Vienna, shares his findings and thoughts with readers in his book about why he came to this conclusion. Of course, you have to read the book attentively and carefully in order to understand Pietschmann's thoughts.

It is certainly no coincidence that Professor Pietschmann and Professor Sxl taught theoretical physics at the University of Vienna and loosened or even broke the intellectual shackles of Galilean scientific thinking.

Pietschmann traces the successful and interesting path of scientific research since modern times, beginning with Galileo Galilei (1564-1642). With him began the new scientific thinking, based only on experiment, detached from human emotions, human standards, human self-righteousness and appeal to God, the Bible and the great Greek philosopher Aristotle (384-322 BC).

Galileo Galilei, with his sharp mind, recognized that Aristotle's teachings were based primarily on human experience and did not penetrate to the basis of mathematically comprehensible laws of physics. Galileo's methods of thought and often only thought experiments were so abstract and mathematical that the lower clergy no longer understood Galileo and feared that Galileo would seduce people to apostasy from God with his new science.

Galileo's scientific thinking methods led to humanity's well-known great achievements in mechanics, technology, electronics, atomic fission, space flight and genetic engineering.

But the fears of the clergy also came true. The new science no longer needed God or the good helping spirits. It had become its own master to the point that it created its own image of the world, which no longer needed God as its ruler. Thus the decline of human ethics increased as the turning away from God took place. The loss of the divine center became the loss of man's humanity.

The world constructed with the help of mathematics and technology was only a part of reality, it was a functioning mathematical and technical model of reality, but not reality itself. It was an image of it and countless people, and above all scientists, were deceived and admired their own work, but forgot that what they were trying to understand was a living being, the creature of the cosmos.

What the intellectuals who believe in science never believe is possible - that so many scientists could be deceived by their own eyes - has been happening for thousands of years. The optical structure of the "celestial sphere", on which we see the celestial bodies, can only be optically depicted on our retina as a surface, just as it can be in pictures of sections of the celestial sphere. Anyone who wants to interpret this surface spatially would have to know the size and shape of the bodies depicted there, otherwise misinterpretations arise about space, the size of the celestial bodies, their mass, distance from one another and speed.

Only those who become knowledgeable and recognize what has come of the correct theoretical findings of Newton's so-called celestial mechanics or what has been made quantitative by calculation with the help of unprovable theoretical derivations (assumed straight light beam and assumed full sphere shape) will understand why astrophysics

is in infinity, or if you like, in the unimaginable vastness of a finite universe today. These speculations cannot be transformed mathematically because they consist mainly of assumptions without any basis for proof. (Recall the statements of the mathematician and cosmologist Tipler, who obviously applies the theory of relativity developed by Prof. Einstein very arbitrarily).

But even a non-mathematician or philosopher who has retained a feeling for form and movement in observable nature doubts the speculatively calculated sizes, the calculated speeds and their distances from each other and from our location on the earth's surface. These speculative ideas do not observe the rules of wisdom that the great philosophers and Professor Einstein, who is mentioned here as a witness, take for granted in order to find the truth or the correct interpretation of what happens in nature.

Due to the misinterpretation of cosmic events and the resulting disorientation of humanity, what had been invented for the benefit of humanity now became the greatest danger for humanity and all fellow creatures, because in the intoxication of scientific success the other side of reality, biology, had been forgotten.

Professor Pietschmann reminds us of this and uses art to show the workings of spiritual forces that cannot be quantified but can only be experienced qualitatively. Often it is the spiritual forces of love, humanity, faith in God or a feeling of security that become actions from which something truly great emerges.

Have we not arrived back at the great Greek philosopher Aristotle, who drew his knowledge from the practice of human experience of the reality and wisdom of nature?

The path that Galileo had outlined has reached an end or goal. Everything that was measurable was measured and everything that could not be measured was made measurable. Everything was weighed, counted and measured, according to this order that Galileo had given.

At the moment, people are feverishly searching for the smallest particles of atoms. One day, they will surely agree that they have found them. Then there will only be one thing left to measure for the hundreds of thousands of people working on Galileo Galilei's "New Science", something that was repressed because it seemed so obviously unimportant and everyone thought they could tell at first glance whether the earth was really a solid sphere.

The curvature of the earth's surface, whether it is hollow (concave) or curved outwards (convex), had never been measured. Not because it could not be measured, but because it was not considered necessary to ever measure it. See the classic curvature measurement by Prof. U.G. Morrow in 1897 in Naples, Florida, USA, which proved that the earth is a hollow sphere.

They saved themselves the trouble and instead formulated the axiom that the earth is obviously a solid sphere.

In mathematics and logic, axiom (Greek for requirement) means a statement from which others can be derived, but which itself cannot be proven in the same theory.

## The question of the correct worldview

Worldviews came and were discarded. They were replaced by new designs or expanded when they no longer corresponded to the new findings.

Worldview systems are conceptually defined by their centers and are usually named by them.

1) The oldest world model is known to us and has been handed down from ancient cultures. It is the sky-centric world model, in which the fixed star celestial sphere is enclosed by the hollow earth shell in the center of an inner world. (Also called world egg) It is depicted in the Bible as heaven and earth and also in all major religions.

The sky-centric world model

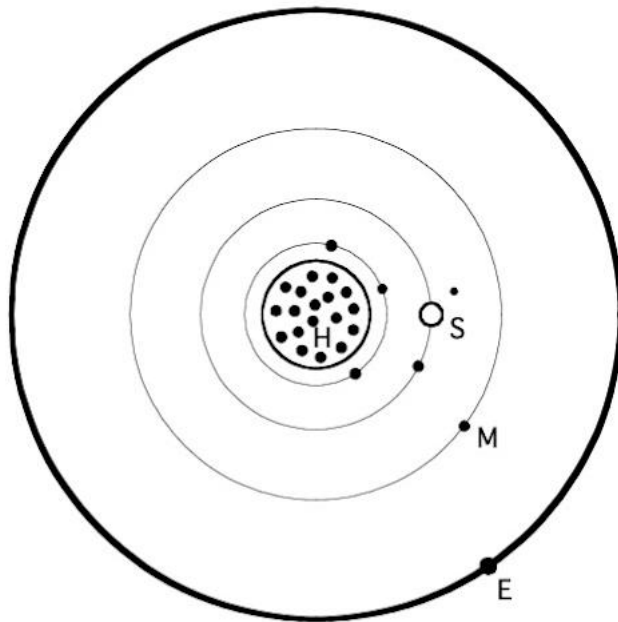

Explanation of symbols:

E = Erdhohlschale

M = Mond

S = sun

H = heaven

The small dots around the sun are Mercury and Venus, within the sun's orbit

The planets Mars, Jupiter, Saturn, Uranus, Neptune and Pluto orbit the celestial sphere.

Fig. 03

2) While the sky-centric model of the cosmos remained anchored in people's religious thinking as heaven and earth, it contradicted the image seen and instead a theoretical model was formed that was necessary for the sciences of antiquity, astronomy and geometry. The globe was now at the centre of this model and was therefore called the geocentric world model. (gea, Greek for earth). Later it was also called the Ptolemaic world model. (After Ptolemy, Claudius, geographer, mathematician and astronomer. He lived from about 85-160 AD in Alexandria, Egypt). Figure 4 shows the earth in the centre of the cosmos, in which the moon orbited the earth, then followed the planets Mercury, Venus, then the sun and the other planets Mars, Jupiter and Saturn. The planets Uranus, Neptune and Pluto had not yet been discovered. A hollow shell of fixed stars enclosed this inner world.

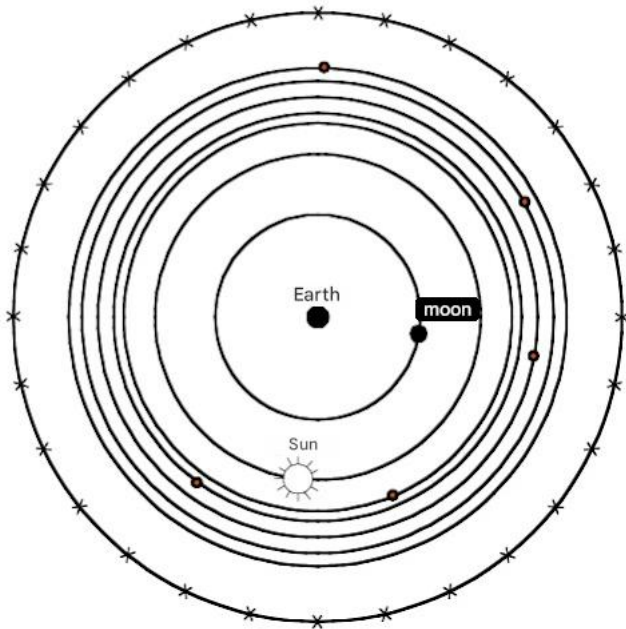

Fig. 04

This model had served people long before Ptolemy, for at least 2000 years as a useful, very descriptive and at the same time theoretical concept, until it was rejected as being too mathematically complicated.

Figure 04 shows the geocentric world model. The earth is in the middle, followed by the moon's orbit, the orbits of Mercury and Venus, then the orbit of the sun and the orbits of the planets. This inner world is closed off by the concave shell of fixed stars that delimits the interior.

3) The heliocentric mathematical model (helio, Greek = sun) presented by Copernicus in the 16th century was considered more suitable by mathematicians and was further developed, particularly by Johannes Kepler.

Copernicus (1473-1543) learned this idea from Greek philosophy.

## The Heliocentric World Model

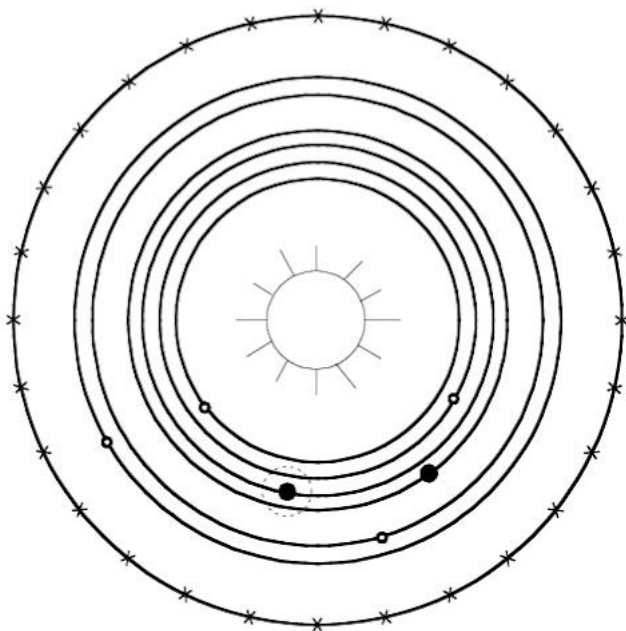

Fig. 05

According to the idea of the cosmos in Figure 05, the sun was at the centre. Viewed from the centre, the planets Mercury, Venus, Earth and the moon, followed by Mars, Jupiter and Saturn, orbit around the fixed sun and all of this was enclosed by the shell of fixed stars to form an inner world.

This model was proposed by Copernicus to make it easier for astrologers to calculate the positions of the planets. This proved to be a failure, as the problems remained the same and calculating the moon's orbit and determining the moon's location were and remain the most difficult to this day. Johannes Kepler (1571-1630) succeeded in mathematically describing the planetary orbits around the sun with his three Kepler laws.

However, over time the idea that a shell of fixed stars would enclose this inner world with the sun at its centre had to be abandoned. This destroyed Copernicus' model of the inner world and all that remained was the solar system in space.

## The Modern Conception of the Universe of Astrophysics

Astrophysicists began their work with Isaac Newton (16643-1727), an English physicist and mathematician, and created the astrophysical concept of the universe that is taught in schools today. Over the centuries, tens of thousands of physicists and mathematicians have worked hard and skillfully to develop a theoretical model of the universe that was just as unimaginable as the atomic model once developed by Rutherford and Bohr, but reached an admirable high level as a computational model, so that this model even made it possible to successfully carry out manned rocket flights to the moon and back.

A model of this mathematical model of the universe cannot be built due to the large distances between the planets and stars calculated using the imaginary straight beam of light, but there are educational trails that attempt to show how small the Earth is in this mathematical model and how large the Sun and the other celestial bodies are, and how large the distances between the individual planets and the Sun and between the Sun and the stars are according to this model.

But is a calculation model developed using mathematical methods the reality of nature?

This question is very easy for researchers to answer because they are used to working with models of all kinds or experimenting with them. If the model produces results that match reality, then it serves its purpose and is good, but the reality of nature is the other thing that is described by the model.

Come with me in search of reality. I have found much of it in models 1 and 4 over the course of sixty years of my life. I invite you to do this and am grateful for your criticism and possible cooperation. Professor Dr. Roman Sexl (deceased), formerly at the Institute for Theoretical Physics at the University of Vienna, was a great help to us, me and the physicist W. Braun, with his criticism and his supporting mathematical formulas.

I want to show you on my homepage [www.weltbildfrage.de](http://www.weltbildfrage.de) that the time has come to bring together the mathematical, theoretical model and the biological model of the cosmos in order to better understand reality in a new, holistic model of the cosmos supported by all branches of science and what this could mean for humanity in the third millennium in terms of progress in all areas of life.

## Reality and its mathematical description

Many people judge the world view of the inner cosmos (sky-centric world model) in the following way: Space flight in the inner world is not possible because a rocket would have to hit the opposite shell of the earth at a distance of about 12,000 km (1) and because the earth was photographed from the moon. (2)

Argument 1 shows a lack of knowledge about the flight technology of a rocket. Argument 2 reveals a partial lack of knowledge about the laws of optics, which seems to be particularly widespread among astronomers. If one assumes that these objections are justified, then it is pointless to concern oneself with this world view of the inner cosmos. In addition, it is argued in addition (3), that the flight paths and distances calculated by space scientists clearly prove the correctness of the heliocentric world view that is generally accepted as reality in schools.

If these calculations were incorrect, it is argued, artificial satellites would not be able to reach their targets as precisely and safely. This objection is a major argument and has such a big impact because almost all educated people equate the mathematical model with reality for lack of better knowledge.

The following presentation provides an answer to this and also shows one of the reasons why the measurement evidence on the earth's surface, which proves the hollow spherical shape of the earth as a fact, is not taken into account after these three arguments, or is even ignored as not provable.

This is where most discussions about worldviews fail.

Where do the interviewees get their confidence in their judgment? Obviously from their trust in mathematics.

Certainly, mathematics with its rules is a very good intellectual tool for describing reality. But, as Professor Einstein tells us in his book "My World View" on page 119: "Insofar as the statements of mathematics refer to reality, they are not certain, and insofar as they are certain, they do not refer to reality."



Consequently, it is a mistake to speak of the theorems of mathematics as if they were laws of nature. Anyone who does so anyway is misleading interested laypeople, certainly not intentionally, but carelessly. Professor Sexl shows this using the example from the book of the astronomer Herrmann, who unhesitatingly transfers the straight beam of light from theoretical physics to reality, thus equating an axiom with the laws of nature and then claims that space travel in the inner world, i.e. the inner cosmos enclosed by the Earth's shell, is inconceivable; because if the rockets had traveled hundreds of thousands or millions of kilometers into space, the world view of the hollow spherical Earth would be judged to be non-existent, even by laypeople who are not competent in astronomy.

Anyone who judges so unscientifically has not learned his lessons as a physics student well enough.

What was done wrong here?

Theoretical conclusions from the mathematical model of the heliocentric world view were simply transferred as a fact to another theoretical system, in this case to the inner world - the cosmos, without considering that this is not possible without prior transformation. Because here, in this system, other theoretical principles apply.

The following example from the physicist's practice shows what theoretical physics and mathematics are capable of achieving and how easy it is to distinguish between reality and the mathematical model when one has both in mind.

The images below show the reality drawn in two dimensions on the left and the transformation on the right. The scientist's task is to describe and calculate reality mathematically. He begins by describing the course of the curved streamlines mathematically in an x,y coordinate system. However, the description is quite complicated in this system. Therefore, he transforms the x,y system (left image) into a new "phi psi system" (Greek letters) using a suitable mathematical function.

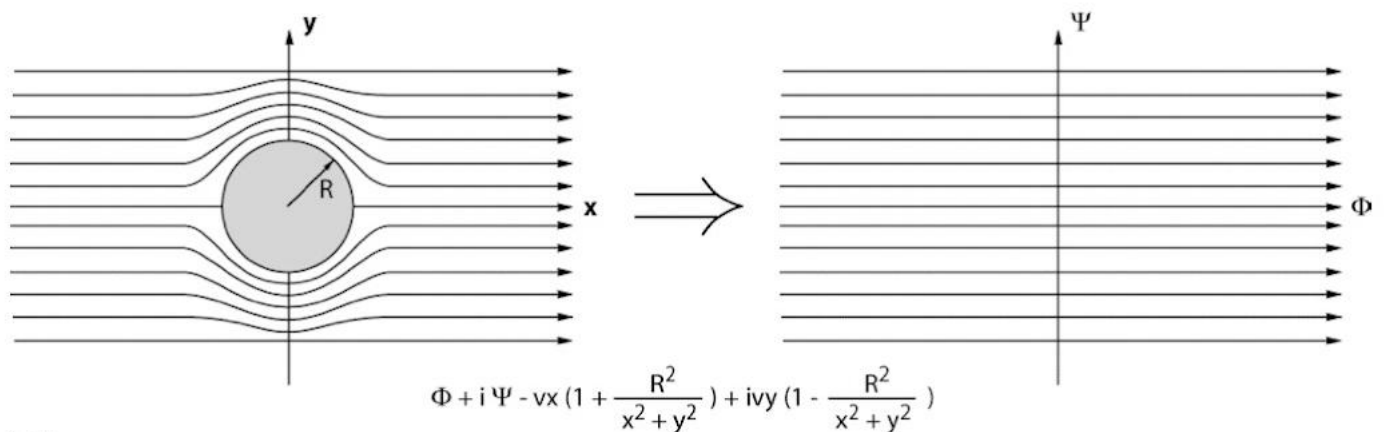

Fig. 06

Each point x y of the original field is thereby transformed into a "point phi and psi image system". By using the above function, the curved streamlines of the original are transformed into straight lines of the image system. The cylinder is thereby (theoretically!) transformed into a thin sheet of metal. From the image model thus obtained, which is mathematically very easy to describe and is of course mathematically closely linked to the original, he can now calculate the desired data such as pressure and flow velocity relatively easily.

However, it would never occur to any scientist to present the image model (right image) as a new reality just because calculations can be made based on it. Even the layman recognizes here that the image model obtained through transformation is not reality itself.

At this point, it becomes clear to the discerning reader that it is a nonsensical argument to claim: If one can calculate the flight of rockets according to the heliocentric (Copernican) model of the cosmos, then this is reality.

On the contrary! Because where calculations are made with a straight line, which does not exist in nature, it can only be a mathematical model of the world.

Our scientific advisor solves this problem regarding the world model for the layman quite simply by using an example, by transforming reality into a mathematical system with the help of a model case.

Reality is where exact measurement results are available and where the form of the world corresponds to the forms of life, as is the case with the sky-centric world view. The large cell organism inner world is essentially similar in form to a biological cell.

Let us now apply the knowledge gained to astronomy and remember that astronomy is still the only science that cannot experiment on the object of its study, apart from the moon. The world is too big and cannot be surveyed, so one can only deal with individual phenomena and try to interpret them. But since the practical work of scientists and astronomers involves carrying out calculations, the reality experienced must be transformed into a mathematical model that makes a relatively simple calculation possible. The Ptolemaic world view with the globe at its centre was such a model attempt, and the Copernican world view has always been, and only scientific enthusiasts, in their wishful thinking, turned the transformation into reality itself.

Copernicus was well aware of this problem, which is why he wrote:

"No one should expect anything from astronomy to be definitely correct. The assumption of the Earth's motion is only an assumption and should not be regarded as an absolute truth."

Every important astronomer of the present and past knew about this problem and only pseudo-scientific works designed to "educate" the people ignore it.

In his book "The Contradictions in Astronomy" (Berlin 1869), Dr. Carl Schöpffer reports on his encounters with the famous scholars of his time.

"I went to Alexander von Humboldt, who never turned anyone away and even answered every letter conscientiously. He received me very kindly and said the memorable words: 'I have known for a long time that we still have no proof of the Copernican system, but I would never dare to be the first to attack it. Don't stir up this hornet's nest; you will only incur the scorn of the undiscerning masses. If a well-known astronomer ever rises up against today's view, I will also share my observations, but I do not have the courage to be the first to speak out against views that the world has grown fond of.'" Dr. Schöpffer continues:

"I informed Prof. Dr. Friedrich Gauss (world-famous mathematician, director of the Göttingen Observatory \*1777-1855) of the progress of my research to date; I told him how I had found that all great thinkers, a Franz von Baader, Schelling, a Hegel, had rebelled against the exuberant assumptions of the Copernicanists, while only the small minds and the uneducated arrogated to themselves the right not only to ridicule as fools anyone who did not join in with the chorus of the current assumptions, but to persecute them with wilder fanaticism.

Gauss, the most famous and greatest astronomer of his time, made no objection to any of these remarks, and on the contrary expressed his complete approval. He even confessed to me that every new discovery in astronomy filled him with new doubts about the prevailing system. But when I told him that Alexander von Humboldt had declared that he would also immediately rebel against today's views if a well-known astronomer declared himself against them, he replied: 'If I were twenty years younger.'"

Quoted from the "Blättern der Wahrheit", Göttingen 1854.

There Dr. Carl Schöpffer wrote (1st volume, 7th issue, pages 354 - 356):

"In order to get to the bottom of the matter, I visited various well-known famous astronomers. I wanted to show one astronomer that the calculations were based on false assumptions, but he replied that what I was citing as the views of the astronomers were not the views of the astronomers at all. I asked how I could learn about the views of the astronomers. The answer was: 'You are making a point. Every astronomer recognizes that the Copernican astronomical system is only an assumption; we do not think of proving its truth and look on it with indifference if someone says it is false.'"

I wanted to make one more attempt and went to a highly celebrated astronomer, who then said: "It is not important to me whether the Copernican theory is true or false, as no real astronomer has ever claimed that it is infallible, but only whether celestial phenomena can be calculated according to it. This is as possible according to it as with any other hypothesis. All astronomical formulas are designed for them, and astronomy will therefore never decide to abandon the laborious work of centuries in order to begin again from the beginning." After a few more objections from the questioner, the astronomer said: "Work out your system and you will find no resistance among astronomers."

This objective opinion still applies today and it would be unwise for someone to try to forcefully break down open doors. It remains an important task to demonstrate the inner connections and to prove that the Copernican system is the transformation of reality. The doctor and cosmologist Dr. Cyrrus R. Teed in 1897 and the lecturer Dr. Bohrmann in the 1930s provided the decisive clues for this.

Figure 07 shows the system of mathematical transformation from the outside world to the inside world.

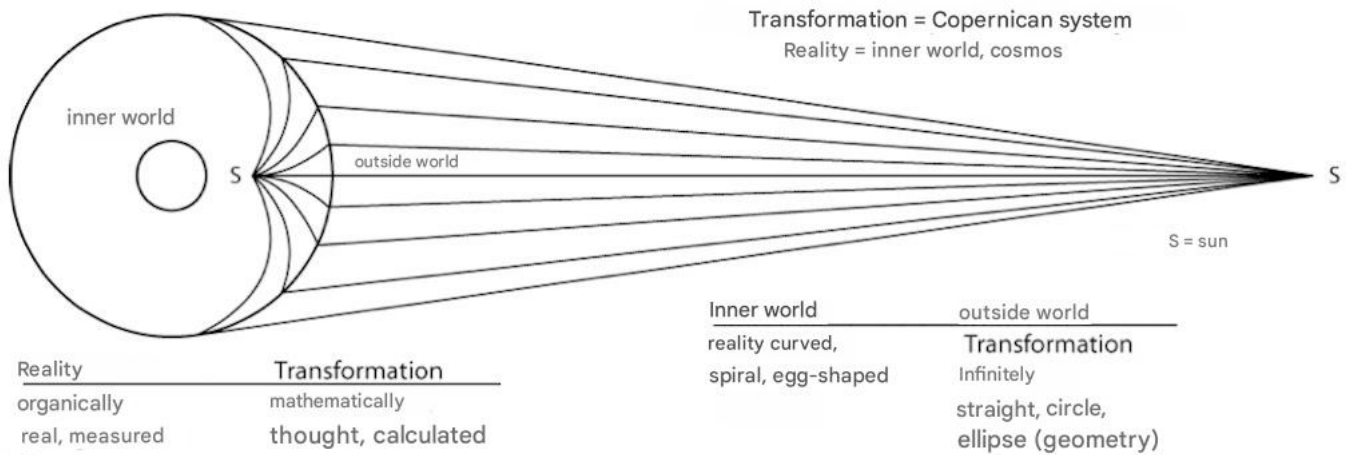

Fig. 07

The lecturer Dr. Bohrmann drew attention to the above transformation possibility in the 1930s, the physicist W. Braun, my specialist advisor, worked out this transformation in more detail and Professor Roman Sexl from the Physics Institute of the University of Vienna gave his physics students the task of mathematically refuting the sky-centric astronomical model (hollow spherical earth with contents). It proved to be impossible and Professor Roman Sexl confirmed in his publications the mathematical irrefutability of the sky-centric astronomical system.

### Does scientific progress without ethical commitment program the decline of human society?

We fly to the moon, have satellites orbiting above us for better television broadcasts, build manned space stations 500 kilometers above the earth's surface, produce atomic bombs and energy from nuclear fission, have missiles that hit their targets and are fired from supersonic aircraft, have developed the art of genetic engineering so that biologists can modify animal species, exchange diseased hearts, kidneys and body parts and, despite this progress and great possibilities, live in a world of ethical decay and turning away from those formative powers and energies that people call good and are summarized in the term GOD THE CREATOR.

Natural laws and norms of behavior that have enabled humans to survive and to occupy a special position in the interaction of living beings are carelessly ignored, so that the balance of power is not only indicated by increasing catastrophes in the natural world, but also the relationship between humans and animals, humans and plants, which is endangered by abuse. But the relationship between humans is most endangered by the exploitation of humans by unscrupulous exploiters who involve humanity in wars that only benefit the instigators and thus plunge highly developed civilizations and cultures into the abyss.

The great achievements with the help of technological progress did not bring about the golden age in a peaceful world of prosperity, but rather the decline of ethical values and disinterest in what is real and true in the world.

The world today appears to us as one without peace and without any great plans for the future. Hardship and disease have increased, unemployment and hopelessness torment many people. What has happened and how can we change it, many desperate people ask.

September 11, 2001 ushered in an era of the most powerful and dangerous terrorism that had never existed before. No one is safe anymore! The unbelievable happened. Peaceful, harmless civilians were used as bombs in the plane they were flying in to reduce the two skyscrapers of the World Trade Center in New York, USA, to rubble and ashes, along with the people who worked in the buildings. There has never been a more barbaric act in the midst of the apparent peace of this world.

The horror caused by this crime is not primarily about finding out why this act of revenge was committed, but rather about realizing that human dignity was severely violated by this gross violation of ethics.

Is this the latest form of war between man and man? If so, then we must ask what the causes of the decline in ethics are.

I agree with the answer to this question that the cause of the decline of ethics is the loss of the DIVINE CENTER in people's consciousness. The knowledge of being responsible before God for what one thinks and does has disappeared because people no longer really believe that God, the Creator of heaven and earth, exists, because in the human consciousness there is no longer any place in the cosmos that could be called heaven.

In the human model of the cosmos, the imaginary realm of God, that is, what was once called the celestial firmament, was systematically dissolved as space and finally diluted to such an extent as a vacuum that heaven as a closed space can no longer be found. In world model No. 1, the celestial sphere is high up in the middle of the cosmos, similar to the cell nucleus in a biological cell. In world model No. 2 and initially in No. 3, heaven as a place was indeed high up, but no longer in the center, but dissolved in an infinity that seemed like non-commitment. Eventually, the concept of heaven was only associated with clouds and space. In the 1960s, the English Bishop of the Anglican Church said to his believers: "Let's be honest, where there is no heaven, there can be no God."

But since people love to submit to an authority in order to be strong together, they created their substitute god as a dictator through ideology in the form of political leaders.

After the end of the First World War, the killing of people for political and pseudo-religious reasons began. reasons to this day. This process is still ongoing and may be beginning to develop, through error and misunderstanding, into a religious war fuelled by fanaticism, as has now become apparent in Palestine. If this killing continues to spread, then this time there is a real danger of a nuclear war.

## Why was the biological model of the cosmos rejected as early as ancient times?

The most important organ of man is his brain and the sensory organs connected to it. If he used it holistically, as animals must do if they want to survive the struggle for life, he would not make the mistake of overestimating his sense of sight and expecting his eyes to do what they cannot do, namely correctly recognize the very large or the very small. Due to their structure, in conjunction with the function of the sense of sight, human eyes are not capable of this, so what is seen needs to be interpreted. This is particularly true when people exceed distances of several hundred meters, where they are no longer able to see in three dimensions.

This first model of the cosmos was rejected by people working in scientific and epistemological terms because the sphere of fixed stars at the center of the model could not be recognized as such. They saw the sphere of fixed stars and interpreted this surface structure as space.

Who among the people of that time or of today is aware that the process of seeing in the eye begins on the retina as a reduction of the reality seen and continues as a mental process, as the latest research shows?

The people of antiquity knew nothing of this, nor of the optical laws, unknown at that time, which meant that the celestial sphere of fixed stars in the center of the inner world had to expand into the celestial sphere, in accordance with the optical laws known to us today.

This is why this celestial-centric world model was rejected not only then, but also today for the same reason, although we now know the human visual process and the optical laws and should take them into account. Unfortunately, I find all too often that physicists do not take the facts described above into account when they talk or write about cosmic phenomena. Anyone who sees the horizon of the sea (the horizon) as proof of the Earth's spherical shape is not taking the optical laws into account. In the past, the sea horizon was the popular "proof" of the Earth's spherical shape. Today, not only among the people, but also among the majority of physics experts (the other scientists who are not experts in the field are not experts anyway), a photograph of the Earth from the moon is considered proof of the Earth floating in space.

**Anyone who, as a scientist of physics, relies on his skills and on the optical laws and the physiology of**

Anyone who knows nothing about vision but presents himself as someone who knows about worldview issues is unfortunately also not competent.

Worldviews are not just pictures of the cosmos, but teachings about the world (Greek: cosmologies). And anyone who is interested in this should read the work of the physicist W. Braun on this website, "The Spatial Metrics in the Inner World".

Here I show you, in Fig. A1, the reflection of the straight light beam on the inner circle. Pay attention to the equal angles formed by the incident straight light beam and the transformed curved light beam.

Both angles are absolutely equal and allow for two completely mutually exclusive distance calculations in cosmic distance measurements, either from the theory using the straight light beam or from the other theory assuming the curved light beam.

How can one determine reality?

Of course, only with scientific methods. This primarily involves measurements and their interpretation. This is the task of the branches of science that are oriented towards reality and the humanities that work with logic and theory under the direction of philosophy.

If an object to be investigated, such as the cosmos or the microcosm of the atomic world, can no longer be overlooked or handled, so that their structures can only be determined theoretically, then the useful theory can in no way be described as reality, because it is only a description of reality and not reality itself. The majority of astrophysicists and atomic physicists who have shaped today's world view believe in the reality of their theoretical models. (See what Prof. Einstein says about the representatives of theoretical physics.)

Wisdom is not based on theories but on experience, and without wisdom there is no certain knowledge.

A cosmos that is no longer understood in its form and function, in its effect and its purpose, leads to disorientation and this in turn can be recognized by the fruits it produces.

Thus, the other cultures and major religions outside the Christian cultural and religious sphere are stunned and shocked by the moral decline of the "Western culture" shaped by Christianity. As technology conquered life in the Western cultures, the ethics of those in power there sank. What once began as the liberation of humanity from slavery, the right of self-determination of people in the political form of democracy, mostly degenerated into a sophisticated system of defrauding voters and led to unbearable slavery by the tax authorities of the states. Never before has humanity been taxed and exploited more heavily, except in a system of slavery.

What is still authority in functioning Christianity is oriented upwards, towards the DIVINE center. The other authority, that is, the one that has power over people and has no ethics, is oriented towards the advantage of its organization, the political party.

There is only one way out of this situation: recognizing reality and returning to God's commandments.

## Geodesy - The science of studying the shape of the Earth

Can we measure the Earth and determine its size? Can we know what the Earth looks like as a whole and what lies beyond the horizon or what it looks like on the moon, on the other planets or even behind the stars? These are ancient philosophical questions and are also related to people's striving for ownership rights and thus rights of use on Earth and in the cosmos, and therefore also to the rulers' search for power and wealth over people.

The educated person knows the answer to all of these questions, but he rarely really knows anything for sure, and yet he believes he does. Unfortunately, some good scientifically based work too often begins with popular scientific presentations with a confession of faith in pseudo-scientific assumptions that supposedly do not require any proof:

For example: "Today every child knows that the earth is a sphere," it begins, "you can even look at it 'from above' on satellite images like an astronaut."

I received exactly this answer from a dear friend when I wanted to start off by giving a somewhat cautious introduction to the cosmos, which was known in ancient times as a large-cell organism, "heaven and earth", and which was proven a hundred years ago by measurements on the earth's surface. For example, that the teachings of that time agree with today's facts, that the earth's surface is the inner surface of a hollow sphere and that all celestial bodies, including the sphere of fixed stars, are located in this interior, surrounded by the protective earth shell.

I had only said a few words in introduction when the above sentence was said to me with great conviction, as if it were a fact "that everyone knows and every normal person knows that the Earth is a ball floating in space and not only the astronauts have seen it with their own eyes, but we have also seen it in the satellite images and the photographs that the astronauts brought back with them".

Anyone who continues to speak in such a situation and does not give in risks a good relationship because he does not share the general belief with others; for this belief is not really knowledge, but only an imagination, an unchecked repetition of what others say or what we have been taught and therefore trustingly believe. Anyone who in this

If someone does not realize in a conversation that it is no longer about scientific truths, but only about the problem of trust, he will lose his previously good reputation because he is questioning the belief system of the person he is talking to. This is perceived as uncertainty, goes against the honor of the ignorant person and provokes contradiction or aggression.

1. How can you tell, without leaving the surface of the Earth, what shape the Earth has, a solid sphere or a hollow sphere?
2. How can you determine exactly where on Earth you are?
3. How can one accurately measure or otherwise determine distances or spaces between different places?

It is the first question in particular that should interest every thinking person and, if answered precisely, will be a guiding principle; because this question is not only about the spherical shape of the earth, but also about the question of whether this spherical shape, which was determined over 2000 years ago by the scholar of the Alexandrian school, Eratosthenes (around 276-192 BC), is a solid sphere or a hollow sphere. It seems that at that time the clarification of this

question was not of particular scientific necessity; because the ideas of the cosmos taught at that time were inner worlds closed off from the outside, in which people felt safe. That is why one idea of the form of the cosmos at that time was a mathematical model, as we received it from the scholar Ptolemy and was needed for scientific purposes, and the second learned idea of the form of the cosmos was the world of the creator god taught by religious philosophy and tradition with the celestial sphere in the middle of the cosmos, as it was presented in religious books (e.g. in the Bible) and also transmitted by Egyptian mythology and by the Greek philosopher Pythagoras, in which people oriented themselves upwards towards the center of the cosmos. (See the bibliography in the appendix)

The mathematical model was used for astronomy, land surveying and orientation.

The biological religious-philosophical model served to answer the questions about God, the meaning of life and the subsequent questions: Where does man come from, why does he live here, where is he, where does he want to or should he go and according to which ethical norms should he behave if he wants to survive in human society within the framework of the natural laws.

Geodesy is a science founded on success and great scientists have achieved great things, and yet famous scientists have only discovered and proven that the Earth is a sphere, or more precisely, a spheroid.

The key question of whether the Earth is a solid sphere on whose outer surface people live, or whether the Earth is a hollow sphere on whose inner surface people live and the cosmos is an inner world, enveloped and surrounded by the protective shell of the hollow sphere, has only been asked by outsiders since modern times; for this was never a question for the official teaching of geodetic science at universities. Their handling of the light beam and the definition once made that the light beam can be used successfully like a mathematical straight line to measure lands and seas did not allow any other thought, because the human sense of sight blocked such ideas.

This is why the impetus for new questions in geodesy came from the scientific field of optics and its findings on light and the eye as a mediator of what is seen. (See: Optics, light and vision)

DIAMGRAM No. 3

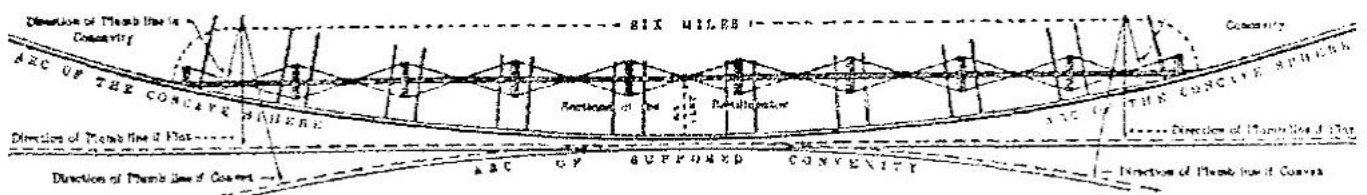

Comprehensive View of the Air Line, Showing Use of the Rectilineator in Survey of Chord of Arc by the Koreshan Geodetic Staff at Naples, Fa.

Fig. 08

shows a graphic of the mechanically constructed straight line of the geodesist U.G. Morrow, Estero, Fla. USA 1897, in its relationship to the concavely curved earth's surface. The possibility of a convexly curved earth's surface or an earth's surface without any curvature could be ruled out according to the measurement results. The simultaneous measurements of the plumb lines in relation to the measuring squares provided further confirmation of the hollow spherical shape of the earth's surface. (See the representation of the classic earth curvature measurement by Teed/Morrow by the physicist W. Braun)

The assumption that the light beam is a straight line has proved to be useful in the general practice of position determination and land surveying. Of course, every surveyor has noticed many deviations of the light beam from the straight line when using his theodolite, but by repeated measurements at different times of the day and over relatively short distances, a value could be determined that met practical requirements.

As will be shown below, it was the light beam and its definition as a straight line that prevented the measurement of the curvature of the earth's surface from even being considered, and the shape of the earth was therefore determined by thinking of it as a solid sphere. It was only the American U. G. Morrow, Ph.D., who constructed a device, had it built and used it to mechanically form a straight line in order to measure and determine the curvature of the earth's surface for the first time in the history of mankind. He called this device the Rectilineator, which means device for forming a straight line.

As so often in the history of science, official geodesy took no notice of Morrow's important scientific measurement and to this day no established geodesist has been found who has processed U. G. Morrow's measurement results or carried out further measurements of this kind. Only chance came to Morrow's aid when the geodesist MC. Nair, also from the USA, inadvertently confirmed Morrow's measurement results with the measured plumb deviations in mines. More about this in the presentation of both measurements and their results.

If one looks at the historical development of geodesy, it becomes clear that apart from the imaginary mathematical straight line, the markings and the theodolite, surveyors generally had nothing that they could use as an aid and tool other than their sense of sight and reason to determine the shape of the earth until the invention of the rectilineator.

Today, since 1970, land surveying has reached a standard with the Global Positioning System (GPS) developed by the American military with the help of satellites, which supposedly allows locations on Earth to be determined with centimeter accuracy. With the help of this technology in conjunction with an additional radio transmitter, missiles can be guided precisely to the pre-calculated targets, as was demonstrated in the 1999 war between Serbia and NATO. But even this system cannot distinguish between solid and hollow spheres in the Earth's body, because it was not designed for this purpose.

Satellite images are supposed to show that the Earth has dents and bumps, so that a deviation of plus 10 meters was calculated at the North Pole and minus 24 meters at the South Pole. However, these and other deviations were nowhere large enough to jeopardize Morrow's measurements with the Rectilineator. If someone wanted to refute Morrow's measurements, they would have to start with facts and also refute the plumb line measurements. So far, no one has made that effort.

The past two thousand years have not seen a uniform development of geodesy. After the first reported experiments of the Alexandrian School, in which the spherical shape of the Earth was determined and its approximate size calculated, there was no further progress for a long time, because it is not easy to measure a distance precisely, especially if it has to be straight and the distances given have to be correct. The science of geodesy is closely linked to cartography, which in turn allows merchants, explorers in foreign countries, shipping and the military to plan correctly in order to reach their desired destination. Not only the width of rivers and sea arms, but also the heights of mountains had to be determined precisely in order to be able to overcome or avoid these heights.

The sovereign wanted to determine the size of his state and, above all, to define precise borders, just as every private landowner must know exactly what his basic rights are.

In the 17th and 18th centuries, geodesists were very busy surveying countries and producing maps that were consistent with nature. All of this was a great achievement, and when it came to the largest structure that man can see, the Earth, the curvature of the Earth's surface, whether it was convex or concave, played no role in influencing the size of the surface. Therefore, there was no urgent need to invent a device that could draw a straight line to the horizontal plane.

## How can you determine exactly where on Earth you are?

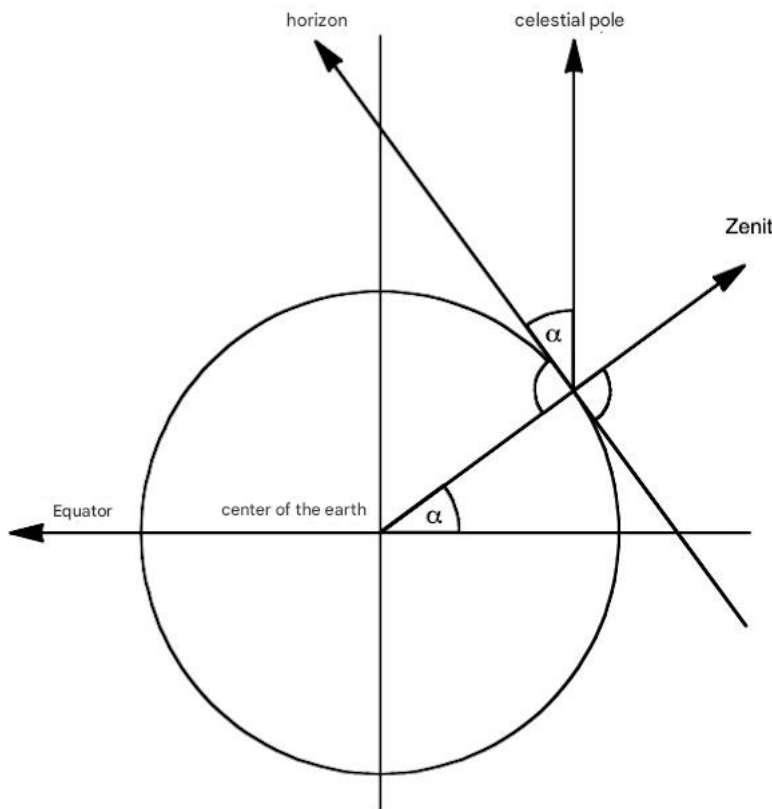

To determine the polar altitude  $a$  and thus the geographical latitude, you level the theodolite and then aim the telescope at the vertical circle on the celestial pole. The angle  $a$  between the horizon and the celestial pole provides the desired value. In the drawing you can see that this is the same angle as the angle between the direction of gravity or the observer's zenith and the earth's equator.

At the North Pole,  $a = 90^\circ$   
At the equator  $a = 0^\circ$

Fig. 09

This question is particularly important for sailors who want to determine the position of their ship at sea. Figure 09 shows the principle of how one can use such a geometric drawing to read the latitude by measuring the angle. This is very easy using the straight line on the circle. Nobody would want to calculate with curved light rays here. In this case, as is often the case, the mathematical model is more successful than reality with its curvatures.

Willibrod Snell's method of base enlargement: using a wooden plank, a very short distance of a few meters is measured (at that time in Rhenish rods). This is the so-called base with the end points  $t$  and  $c$ . From these points, the points  $e$  and  $a$  are selected, e.g. towers that can be seen from afar, so that these can be aimed at when measuring the angles etc. and etc. with a quadrant or theodolite. From the laws for plane triangles, he obtains the angle  $tec$  and the sides  $ec$  and  $et$ . The triangle  $tac$  is determined in the same way. The angle  $eta$  is obviously

$$eta = etc + cta,$$

and since the two sides are called  $et$  and  $at$  as well as the included angle  $eta$ , he can calculate the distance  $ea$  using the cosine theorem developed by Regiomontan:

$$ea = \sqrt{te^2 + ta^2 - 2*te*ta*\cos\langle eta \rangle}$$

line  $ea$  now serves as a new basis for calculating the large triangles  $ema$  and  $eia$ , which, using the same method, leads to the determination of the distance between Leiden  $i$  and Soeterwoude  $m$ . (note: Leiden and Soeterwoude are towns)

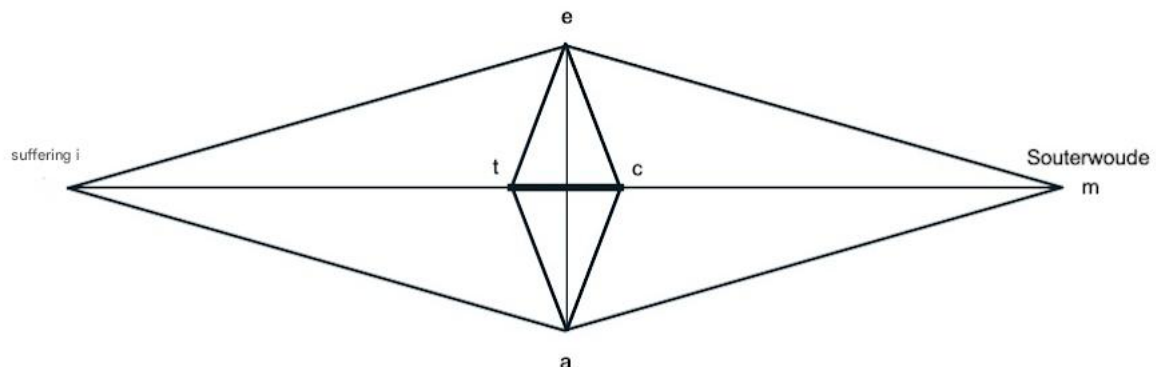

Fig. 10

What really mattered in cartography was the correct distance, size and height information. These 40



Problems were solved by using triangulation. It all began in the 16th century when the French doctor J. Vernel attempted to measure degrees for the first time. He drove his car a predetermined distance and counted the number of revolutions of the wheel. Since he knew the circumference of his wheel, he was able to calculate the distance. This was the first time he had put the idea of the odometer into practice, which is now an important measuring device in every car for reading the number of kilometers driven and for determining the speed at which one is currently driving. All distances on road signs today have been practically determined in this way and are used to produce accurate maps. But this was not enough for the military administration, because the artillery needed distances from place to place as the crow flies, and this could only be done with the help of a light beam. Also worthy of mention is Gemma Frisius, who laid out a base line between the two church towers of Brussels and Antwerp. Additional points were aimed at using a sighting ruler on a circular disk divided into degrees, similar to a quadrant. It was important that this circular disk was oriented exactly north using a compass. The intersection points of the directions drawn on the drawing board were determined graphically. From the points thus obtained, the procedure was

continued in the same way. It therefore consists in "cutting off" new measuring points. However, this method suffers from the fact that the length of the base line is not known. The distance between Brussels and Antwerp was not known and was assumed purely theoretically by Gemma Frisius. The discovery of triangulation by the Dutch mathematician, astronomer and cartographer Willibrod Snell freed people from the previous approximate or inaccurate direct distance measurement. He was fascinated by the method of being able to determine the location of a point on the earth's surface precisely by calculating the sides of a triangle and measuring the angles. In this way (1618) he was finally able to make geodesy independent of direct and very difficult distance measurement and all methods based purely on sensory perceptions (except for sight, of course).

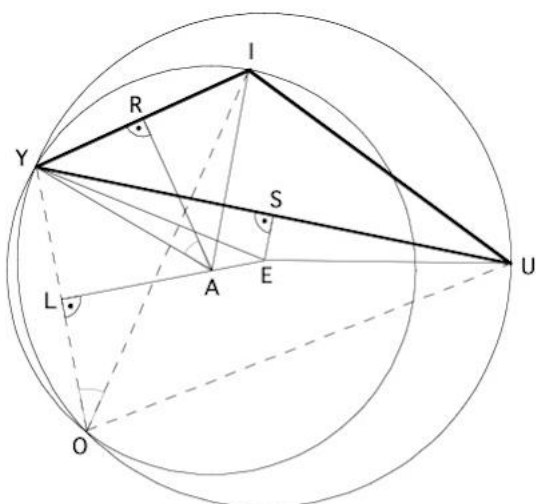

In the course of his triangulation method, Snellius also solved the problem of the "recession problem", which is now known as Pothenot's problem or also as the "recession problem". (But it should be called Snellius-Pothenot's problem.) Hipparchus already dealt with the problem in astronomy that in order to determine the ephemeris of the sun's orbit, one had to find the point near the center of a given circle at which the rays form right angles with each other after three known points on the periphery of the circle.

Snell formulated the problem as follows: If the distances between three given points are known, then the distances to a fourth point are also known, from which one can observe the three points and measure the corresponding angles:

What is needed is the distance between O and I, which he derives from the given distances between Y, U and I and the observed angles YOI and YOU. The geometric construction required for this is as follows: If you connect the bisectors of the lines YI and YO and those of YU and YO, you get from the intersection of the first two the center A of the circle with radius YA on whose periphery the points O, Y and I lie. From the intersection of the last two you get the center E of the circle on whose periphery O, Y and U lie. Then the radii are:

$$YA = YI / 2 \sin \angle YOI \text{ and } YE = YU / 2 \sin \angle YOU.$$

In triangle A E Y, two sides and the included angle are now known, so the angle A E Y is also known. Since L E is the perpendicular bisector of Y O, Y O can also be calculated:

$$Y O = 2 Y E \sin \angle A E Y$$

Then O U in triangle O U Y and O I in triangle O I Y are calculated. And thus the required sides O Y, O I and O U are known.

Fig. 11

As a by-product, the original method of triangulation was created, which is still used to this day, in addition to the refinements by Gauss and others, to measure the exact size of the Earth. But the actual measurement that gave this method its basis was still missing. So he actually measured a small piece of a few meters very precisely, made from a double row of specially made wooden slats that he moved against each other. (Fig. 5.3) Using triangulation, Snell laid out a network of triangles and was thus able to calculate the distances. In the Württemberg land survey (1624-1635), which was carried out on the initiative of the Tübingen orientalist and mathematician W. Schickard, the trigonometric network was constructed exactly according to Snell's method. However, a distance of 3900 feet in length near the Neckar was directly measured as the actual measured basis and then used further using the method of base enlargement. The events of the Thirty Years' War and the death of Schickard stopped this undertaking. The first major surveying project was undertaken by France in 1671 under the leadership of the astronomer Picard, who had the crosshairs installed in the telescope, which had been invented and introduced at the beginning of the 16th century.

Following the example of France, almost all European countries that were well administered were soon systematically surveyed and recorded, mainly for military reasons. The genuine continuation of the method of triangulation, as well as the further development of theodolites and the precision mechanics of this device, had a lot to do with the famous mathematician and practitioner Gauss. He ushered in a new era in science in terms of precision and profound thinking. The conceptual developments he developed went far beyond his time. He was also the one who came up with the so-called reference surface of the celestial sphere (the optical magnification

Dos Snellius's network of 23 different prominent towers of places in the Netherlands (left) and the marked distances between the individual places calculated by base magnification

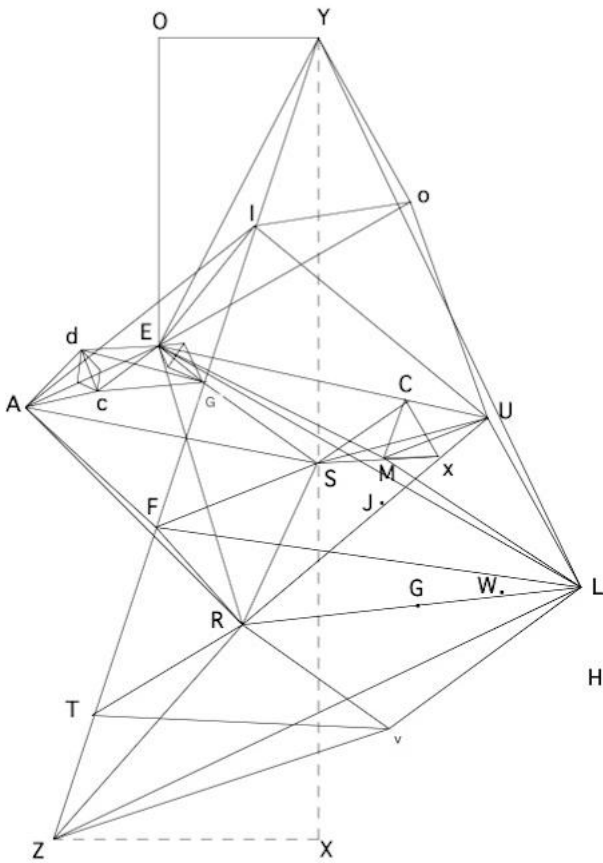

- c
  - d
  - e
  - f
  - g
  - h
  - i
  - j
  - k
  - l
  - m
  - n
  - o
  - p
  - q
  - r
  - s
  - t
  - u
  - v
  - w
  - x
  - y
  - z
- = Amsterdam
- = suffering
- = Rotterdam
- = Breda
- = Beergen op Zaam

Fig. 12

of the celestial sphere from the center of the sky to the horizon) for 10 years, but could not find the cause because the heliocentric world view, to which he was bound by mathematics, did not allow him to see the solution to the problem.

## And how do you measure the angles of triangles?

To do this, you use a theodolite. You point the telescope with the crosshairs exactly at the vertex of one object and read the angle on the horizontal circle. Then you point the telescope at the second object, read the angle again and the difference between the two readings gives you the angle you are looking for. This is

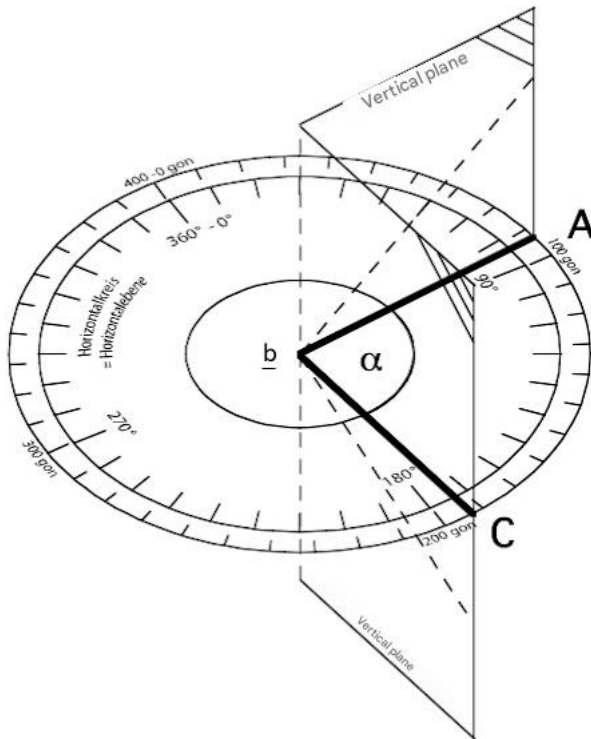

The theodolite is used to measure the angle  $\alpha$  between observer B, where the theodolite is centered and leveled, point A and point C. To do this, point A is targeted, the horizontal circle (the horizontal circular disk divided into 360°) is read, then point C is targeted and the angle on the horizontal circle is read again. The difference between the angles read is the angle  $\alpha$  that is being sought. You can see that due to the design of the theodolite, only horizontal angles are ever measured.

(Today, for the sake of easier calculation, 360° has been replaced by the unit 400 gon.)

Fig. 13

the horizontal angle between the two objects, i.e. the angle between the points on the plane, which is determined by the horizontal circle of the theodolite. The fact that you always measure horizontal circles with a theodolite is what makes this device special. If you measure an oblique line up to the tower, a straight horizontal line to the base of the tower and the height of the tower, you form a vertical triangle, i.e. not lying horizontally.

The problem that the angle between the oblique lines is not the same as that between the horizontal lines does not need to be taken into account because the error is so small. There are of course many sources of error hidden in all measurements, but these can be compensated for if you recognize them. Today, the technically very advanced theodolite has a vertical circle in addition to the horizontal circle for measuring elevation angles.

## Can one measure the curvature of the earth's surface using such a precision theodolite?

Prof. Dr.Ing. Hohenner shows in his work "Geodäsie" Leipzig 1910 on page 249, illustration no. 13, which shows what happens when you aim from place A to place B. The theodolite shows place B at B'. Since the light beam is usually assumed to be identical to the straight line, the light beam must bend in this case if one assumes a convex curvature of the earth's surface. The cause is then assumed to be that the light beam is bent or refracted as it travels through layers of air of varying density. Such refraction or diffraction is called refraction. This is a justified assumption, but not proven by anything. It is an explanation of how it could be; if one adds the further assumption that the earth's surface is convexly curved like a solid sphere. This results in a certain constant value, related to the distance, which has been found on the basis of experience. But all of this has nothing to do with exact measurement and does not answer the question of whether the Earth's surface is concave or convex.

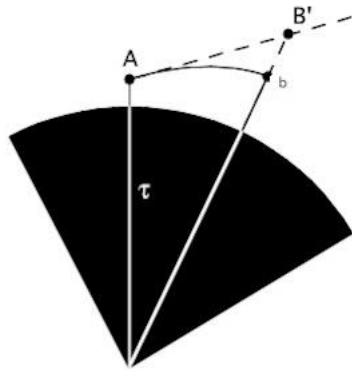

The theodolite shows the location B on our drawing at B' even if it works with great "precision".

Fig. 14

On page 249-250 of his book "Geodesy", Prof. Dr. Ing. Hohenner provides the following additional important information: "Experience has shown that the light curve A-B can usually be understood as a circular arc with the radius  $R_i = R/k$ . K is the so-called refraction constant and R is the radius of the earth. The table printed on page 250 of his book shows the value K (0.13). The correction is then for a distance of

500 m	= 0,017 m	5000 m	= 1,705 m
1000 m	= 0,068 m	10000 m	= 6,820 m
2000 m	= 0,272 m	20000 m	= 27,200 m

Professor Dr. Ing. Hohenner gives the calculation formulas for the "trigonometric height calculation taking into account the curvature of the earth and refraction of rays" and concludes with thankfully short and clear statements: The refraction of rays therefore counteracts the (convex) curvature of the earth.

This means that simply assuming light refraction compared to the imaginary straight line results in almost exactly the same differences as the assumed convex curvature of the earth. It is therefore clear that the entire calculation is based on two assumptions: the convex earth and refraction. This means that the calculation is merely a useful mathematical interpolation.

If we look again at Figure 14 from the point of view we have now gained, it becomes clear that the line of sight, which seems to extend high above the targeted location, is as much as the depression of the imaginary convex earth surface of a solid sphere according to Gauss' constant (K).

However, if the target location B is on the surface of the earth in a hollow sphere, it is twice as high. In order to make a correct statement here, the measurement results are evaluated and finally a refraction theory is developed, which must be proven on the mechanically formed straight line.

The inaccurate information, which was criticized by Prof. Dr. Wünschmann in his "Handbook of Physical Optics" (Leipzig 1927), for example, and which had to be corrected using the value (K), led him to state (page 279): "The radius of curvature of the light beam is usually smaller than the radius of the earth, while in the case of general refraction it is seven to eight times as large."

The fact that accurate results can still be achieved horizontally is due to the fact that errors can be identified and corrected and, above all, to the fact that short distances can be measured where the value (K) is low compared to long distances. This fact shows a possibility of measuring a long distance using many such short distances and comparing it with the result of the long-distance measurement. The differences that arise here would certainly provide interesting information, if interpolation were initially omitted, which would be expected according to U.G. Morrow's classic earth curvature measurement.

Unfortunately, measurements using mechanical measuring instruments are very time-consuming and therefore very expensive. Without sponsors, it would not have been possible to carry out the many light and ether measurement experiments in the last century, which were finally interrupted in the 1930s due to a lack of money, because a war again hindered cultural progress.

This answers the main question above and the answer is that no convex or concave curvature of the earth's surface was measured with the help of the precision theodolite. This was not possible with the help of light rays, because geodesy proved that there is no straight-line propagation of light. What is still missing today is a refraction theory that corresponds to the facts. One could at least obtain results in a series of experiments on the refraction of light and use these experimentally, but unfortunately the main question always remains who wants or should carry out these experiments and for what purpose, as well as who processes and secures the results and who pays for them.

## Measurement experiments

Since U.G. Morrow's 1897 measurement with the Rectilineator showed that the curvature of the earth's surface was concave, experiments with a short light beam of 500 m in length are useful in order to develop a theory of refraction based on this measurement. I propose the following method:

On a fairly flat area of approximately 3-5 km in length, a straight line is formed using a precision theodolite. A measuring rod is anchored in the ground every 250 m and the level is measured. Using a communicating tube filled with liquid, an artificial sea level is formed using the method designed by Dipl. Ing. Ernst Zunkel. This line should remain stationary over a longer period of time for measurement tests and be able to be monitored.

The values of the Gaussian constant "K" indicate that in the relationship between the light beam and the sea level as an imaginary full sphere of the earth, at a distance of 500 m there is a difference of 17 millimeters opposite the earth's surface.

before it is created. If you double the distance to 1000 m, this constant, "K", quadruples to a value of 68 mm. At a distance of 5 km, "K" is already 1.705 meters. If you divide the 5 km into 10 sections of 500 m, the value "K" of 0.017 m = 0.085 m occurs 5 times. Compared with the constant for 5 km, this results in a difference of 1.62 meters. These values relate purely theoretically to the curvature of a full sphere and a light beam defined as approximately straight, from which the Gaussian constant is composed. What do these determined values mean under the assumption of the result of the Morrow measurement, which demonstrated a concave curvature of the earth's surface? In any case, one could determine the value of the curvature of light and form a refraction theory by experimenting and from the facts then determined.

Cosmologist Johannes Lang writes in connection with his efforts to find solutions to measurement problems:  
"No one will dispute the importance of such continued measurements for the exact detection of the refraction of light.

Especially for astronomers, knowledge of the function of light propagation and knowledge of the true shape of the Earth would be of crucial importance;

because from this knowledge it becomes possible to recognize the form and structure of the cosmos."

Most people were deceived by their sense of sight because they believed what they saw with their eyes or through a telescope without checking it. Where so many scientists today proudly point out that real progress began when science gave priority to measurement instead of following human sensory experience, here they themselves fell for the sensory experience of "sight" when determining the shape of the earth and the entire cosmos. When U. G. Morrow, Ph.D., discovered this error, it was no longer possible to correct it with the "established teaching system" of universities and schools. The fact that this is a psychological problem and not a scientific one has already been pointed out and unfortunately has a very inhibiting effect on knowledge and leads to errors caused by optical illusions.

## Optical illusions

The two most well-known optical illusions that we encounter every day are the celestial sphere and the horizon. Anyone who believes that both are real without asking about the laws of optics is on the wrong path. The self-deception begins with the belief that the horizon shows the curvature of the Earth and that this is proof that the Earth is a full sphere. It is just as wrong and unscientific when horizon images of the Earth's surface from space, which capture a small circle of the Earth, are claimed to be proof that the Earth is a full sphere.

The same applies when scientific writers describe the small, round disk of the earth, photographed from the moon and glowing in bright colors, as a globe, although they should know that our human eye and optical devices are no longer able to provide spatial vision beyond a certain distance. The limit of spatial vision for the normal human eye is around four hundred meters. If the viewer is shown an unknown and unusual structure, the ability to see in three dimensions ceases at a distance of around seven meters. Professor Dr. Ebbecke researched this and presented it in his book "Reality and Illusion". One of his most interesting experiments was the painted representation of a colored hollow human face mask, which could only be recognized as a hollow mask with great difficulty, because not only the

eye was unable to identify the surface of the impression perceived on the retina of the eye as a hollow surface, but also the unusualness of a hollow, artistically painted face. A one-eyed person or a normal camera cannot identify with certainty a concave (hollow-curved) or convex (curved) surface of an object. When looking at an image surface, e.g. a photograph, no human can tell whether the object is a solid sphere or a hollow sphere.

I had my hollow sphere globe photographed and presented the photograph to viewers. Everyone can only

Identify the shape of a sphere, but not whether the curvature of the sphere is concave or convex. A scientist must know that this is the case from physics class, or he learns it quickly from experience or from others.

Since I was familiar with these optical laws, I was able to write in a brochure on the visual representation of the inner world as a sky-centric model in the text explaining its form and function back in the 1960s, after the first publications of images of the Earth taken by astronauts from the moon with a camera: "... no scientist of any standing could describe this intensely colored image of the Earth as proof of the Earth's full sphere." And it has remained so up to the present day in 1999. The physicist W. Braun dealt with this optical problem in detail in the scientific paper attached to the manuscript, which was published at the time. It is really regrettable and also irresponsible when non-specialists deal with scientifically clarified optical phenomena in such a superficial and careless manner, either out of ignorance or against their better judgment. The sentence mentioned above, that even children know that the Earth is a sphere (full sphere), fits in perfectly with this.

## Conclusion and Conclusions

If you look at the measurements taken by geodesists, you will see that they use the light beam and the theodolite to measure angles and calculate distances using mathematics and trigonometry. As long as this is done on the surface of the earth and a base measurement has actually been taken, these calculations are very close to reality.

Since astronomers use the same methods to calculate the distance of the sun, moon and stars, and have a correctly calculated radius of the earth as a basic measurement, but cannot check whether the calculations are really correct when measuring angles using light rays, numerical information about distances is without any evidential value, because experience has shown that the light beam used to measure angles is never absolutely straight. Geodesists have it easier than astronomers in this respect, because their object of measurement is the earth's surface, which is accessible and the measurement result can be checked in practice.

On the moon, astronomers had a chance to measure its surface using the wheel rotations of the lunar cart or the mileage counter on the lunar rover. Unfortunately, NASA announced at the time that the mileage counter was defective. Nothing more was known at the time, and even though it is unlikely that such a technically simple device could have failed, the only assumption that remains is that the values determined could not be recognized as correct because they do not match the expected values. It would be very helpful if we could find out the original values of the mileage counter that was declared defective today. I have since received information that these values are not known by all

moon landings should have been published. I will obtain the data and evaluate it.

Angle measurements require an absolutely straight light beam. Not only is there no proof of this, but it is also highly improbable that light can propagate in a relatively straight line over long distances in the assumed empty space, because what the French professor of physics and Nobel Prize winner Maurice Allais, Paris, now 92 years old, demonstrated with a short light beam of 8.30 meters, extinguishes all hopes of a straight light beam; because in his experiments this short light beam bent in periodic fluctuations of 1.5 millimeters. See the description of Professor Allais' experiments with the light beam and the pendulum. (See reference)

U.G. Morrow put an end to the assumptions and conjectures about this with his classic measurement of the earth's curvature. His measurement is presented here in this manuscript and was examined for methodological errors by the physicist W. Braun. The measurement is exceptionally precise and well documented and is available as a book in English today for around \$30, but, as our research has shown, is only on display in one library in the world, namely the Library of Congress, Washington DC, signature no. QB 638. T 255-40838.

## On the Problems of Geodetic Measurement Technology

Measuring a straight line on an earth surface that is curved everywhere is not easy, especially on the surface of a sphere, whether it is convex or concave; because measuring and forming straight lines is particularly difficult.

When measuring the size of land areas and their topography, it is sufficient to create a straight line that does not deviate to the left or right in its alignment. Whether the earth's surface is convex or concave does not change the result. The measurement is initiated by walking in the desired direction, marking out the distance with the red/white marked rulers and then aligning the rulers with the help of the light beam. I discovered that if you lay

this line in the morning and checks it in the afternoon to see that the line formed with the help of the light beam is no longer straight. Since the scales have remained in the same place, only what we call the light beam can have changed. (Experiment with surveyor W. K. Wavruska and his measurement protocol.) The average value is then adopted. Since small distances involve small deviations from the expected straight line, this is the way to proceed. However, when it comes to distances of many kilometers, not only an average must be taken, but also corrections must be made. But that is also quite OK and has led to great progress.

The straight line determined in this way does not provide any information about the differences in height; these are determined and calculated separately using angle measurements.

However, if you want to create a straight line and a horizontal straight line, the measuring sticks are not enough; the horizontal straight line must be constructed mechanically on the straight line because experience has shown that the light beam is not straight. This requires an extraordinary amount of time, personnel and money and was therefore only carried out once using U.G. Morrow's method. Anyone who is bothered by this should carry out further measurements or advocate and promote that they be carried out. Anyone who acts or speaks differently is not a scientist in Galileo's sense.

It is therefore not enough to simply form straight lines and then form angles with the help of the proven non-straight light beam and use these to calculate distances.

use; because if you transfer this method to cosmic scales and accept the values determined without being able to correct them as if they were facts, then the unrealistic but calculated result comes out, which is today represented as space with its infinity in space and time. This fantasy of the infinitely large, the

infinite vastness and limitlessness, determined from the redshift of light, leads to illusions and

**Misjudgment of the basis of human life; because if a person believes in the facts given by astrophysicists**

If one believes in results and lives accordingly, one will fail because of the illusion and the measures and numbers that are not proven by anything.

Of course, there will always be people who can get intoxicated by conceivable fantasies and proclaim this as a creed, but ultimately cannot recognize reality.

## Degree measurements as evidence for the concave curvature of the Earth's surface

When, more than two thousand years after the first calculation of the circumference of the earth by the scholar Erastosthenes, people began to determine the circumference of the earth again by trying to calculate the distance between two degrees of latitude, they agreed that the circumference of the earth was 40,000 kilometers. Later repeated measurements could not confirm this result, as new measurements always produced different values. The scientists in charge of the subject therefore agreed on a correction of 40,000 km plus 3423 km. (1922) The current data for the circumference of the earth at the equator are 40076.594 km and 40009.153 km at the poles. If you consider that the earth cannot be an ideal solid or hollow sphere and that degrees can only be measured trigonometrically and then calculated, this figure is also the best possible that could be achieved. This figure has certainly changed due to measurements taken by satellite. In any case, it is clear that degree measurements are possible and this opens up another possibility to prove, using another method, whether the Earth's surface is the inner surface of a hollow sphere or the outer surface of a solid sphere.

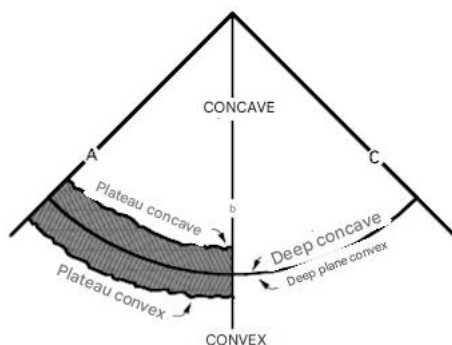

Explanation of the drawing:

A, B, C = plumb lines that converge upwards in the case of a concave earth shape, but diverge upwards in the case of a convex earth shape. The plateau running from A to B is "concave" shorter than convex. The lowland running at approximately sea level between B and C is practically the same length in both systems and can therefore be used as a comparison object for measurements

Fig. 15

How long is the distance between two degrees of longitude at the equator (sea level) when the earth's diameter is 12756.776 km?  $12756.776 \text{ km} \times 3.14 = 40056.277$ : 360 degrees = 111.267 km length from degree to degree. However, if you measure the distance between two degrees at a height of 2.5 km, the following differences arise between a solid spherical earth and a hollow spherical earth:

The radius of the solid sphere increases mathematically by 2.5 km at a height of 2.5 km, so that the diameter increases to 12761.776 km. Diameter times 3.14 = 40071.976 km circumference divided by 360 degrees 111.311 km length for 1 degree. The radius of the hollow sphere decreases by 2.5 km at a height of 2.5 km, so that the diameter value is now 12751.776 km. Diameter times 3.14 = 40040.577 circumference divided by 360 degrees = 111.238 km.

The calculated difference between the two earth concepts to be compared is 73 meters at a height of 2.5 km and is no problem for today's precise measuring technology used by geodesists. Geodesists can determine the end points of a triangulation to within a centimeter.

## Thoughts on optics

Our eye is an organ that transmits light impressions, and the physical phenomenon of light is not easy to explain. When it comes to explaining the process of seeing, from the arrival of the electromagnetic oscillation of light through the lens of the eye and the radiation of the impulses onto the retina, it is even more difficult to correctly classify and understand all the connected processes. It is quite obvious that the networking of our brain functions with what we call soul and spirit is much more intensive than was imagined in the materialistic 19th and 20th centuries.

The pure light impulse passes through the pupil as a very small straight line to the lens and is directed to the retina by refraction and deflection in order to reproduce a small, two-dimensional image of the large external surface as a chemical reaction. The small straight line is the measurement basis of human vision and indicates the direction from which the light impulse comes when it hits the retina. The retina registers the strength of the light impulse and the color values it contains and passes these impulses on to the brain for processing. The miracle of vision is the processing of these impulses in the brain to create the external image that is ultimately seen, which corresponds very well to reality up to a distance of around four hundred meters through spatial vision with the two eyes set apart and is supplemented by visual experience.

It is understandable that people of earlier centuries or millennia may not have known so much about these things and came to false conclusions when describing and assessing distant objects, but that people of our time act as if they could see objects such as the moon at a distance of around four hundred thousand kilometers through the idea that the visual organs eye and brain can judge reality accordingly is frivolous because it contradicts all knowledge. (Read the explanation of the physicist W. Braun) If someone says that one

can see objects such as spiral nebulae, other universes and black holes etc.,

He is right that one sees something, but this "something" is then interpreted on the basis of presupposed assumptions, hypotheses and theories. This has to do with reality only in the aforementioned limitation and is serious

This is only possible if one states the conditions under which one arrived at such interpretations. These methods of interpretation are known to experts, but not to laypeople.

It is the sense of sight that irritates people and it is the phenomenon of light; its quality acts as a wave in the medium of ether and also like corpuscles and therefore must

All of this needs to be investigated in a sober, scientifically accurate manner, so that the knowledge gained can be used in practical research.

## The horizon circle as the optical basis of the celestial sphere

The horizon circle completes the real basis for the exploration of the Earth and the celestial sphere. On this only optically We stand as observers on a round piece of earth and optically form the centre of the surfaces of the space around us. Nothing works without this place, to which the movements of the celestial bodies are related. But what does the horizon represent? It is the optical limit of vision of the observer. If he uses a telescope, his horizon expands. Uneducated people often describe the earth's surface as a large In the past, the horizon was thought to represent the curvature of the Earth. The altitude researcher Piccard could still see the horizon from his balloon at an altitude of 30 km, similar to how everyone can see it today when flying from an altitude of about 10 km. Piccard bowl around him up to eye level. At what height does this view of the horizon end? Unfortunately, I have not heard or read anything about this from astronauts; because just as the earth optically becomes a small disk, with high light intensity, must occur at a certain height with the transition from the horizon circle to the disk of the earth. If you look at the films shown on television of astronauts working on the space station at around 200 and 600 km altitude, the horizon still seems to be at eye level

The astronauts had particular difficulties with what they perceived as the horizon on the moon.

There was no horizon like on Earth, because everything was completely different. The pictures of the moon suggest a lot. Above all, there was no atmosphere and estimating distances was not possible because the lighting conditions were different and there were no trees, houses or known comparison objects visible that would have made comparison possible. I experienced this uncertainty when estimating distances and the size of stones or rocks in the high mountains. Without a comparison object, at least a human, estimation was not possible.



## How is the horizon formed?

It is a fact that it represents the optical limit of vision, and what we see as the horizon is formed on the vault of the retina of our eyes. Since each retinal cone has a certain size, the angle of vision of an object that this object forms on the retina in the eye is crucial. If it falls below 1 arc second, the object can only be perceived as a point. All objects, surfaces, bushes, trees, houses or living beings that can only be seen at this angle merge into the horizon line at eye level in the distance at the limit of vision. If an object extends beyond this eye level, you can see its upper part, while the lower part merges with the horizon line. Towers, mountains and chimneys or masts of ships, the smoke from chimneys, etc. remain visible because they form a larger angle of vision.

Figure 5.9 shows this schematically. Even in the extreme case of an absolutely flat surface, the lower part of an object on the horizon would have to remain invisible and the impression would arise as if the surface behind the horizon had sunk into the distance. From this, the layman or those who are not familiar with the principles and laws of optics conclude that the invisible surface behind the horizon must have sunk, thus confirming the optical impression that the earth's surface is the outer surface of a solid sphere. As the schematic sketch shows, our vision is an optical process that takes place via the eye organ and allows vision

about the nervous system, the brain, mental reproduction and understanding through experience and interpretation.

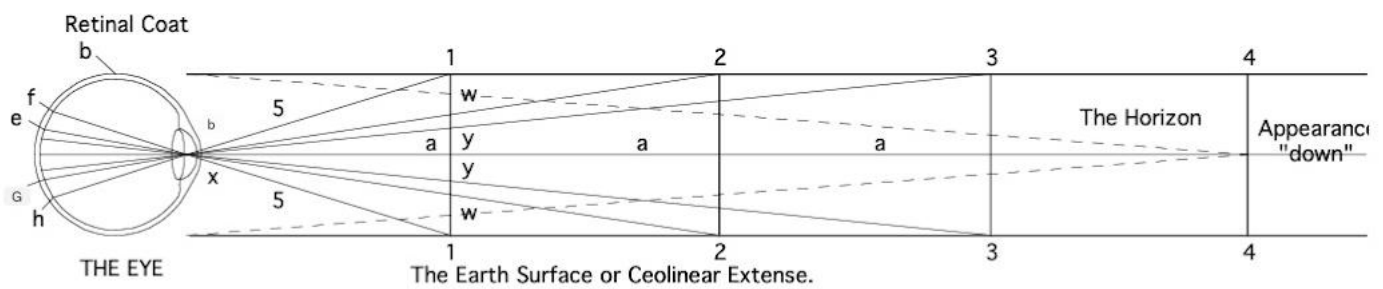

DIAGRAM No. 1. Illustration of the Laws of Visual Impression.

Fig. 16

The illustration also shows why the horizon is always at eye level: because it is an optical phenomenon formed in the eye. Therefore, an optical phenomenon such as the horizon cannot be proof of the hollow spherical or solid spherical shape of the earth.

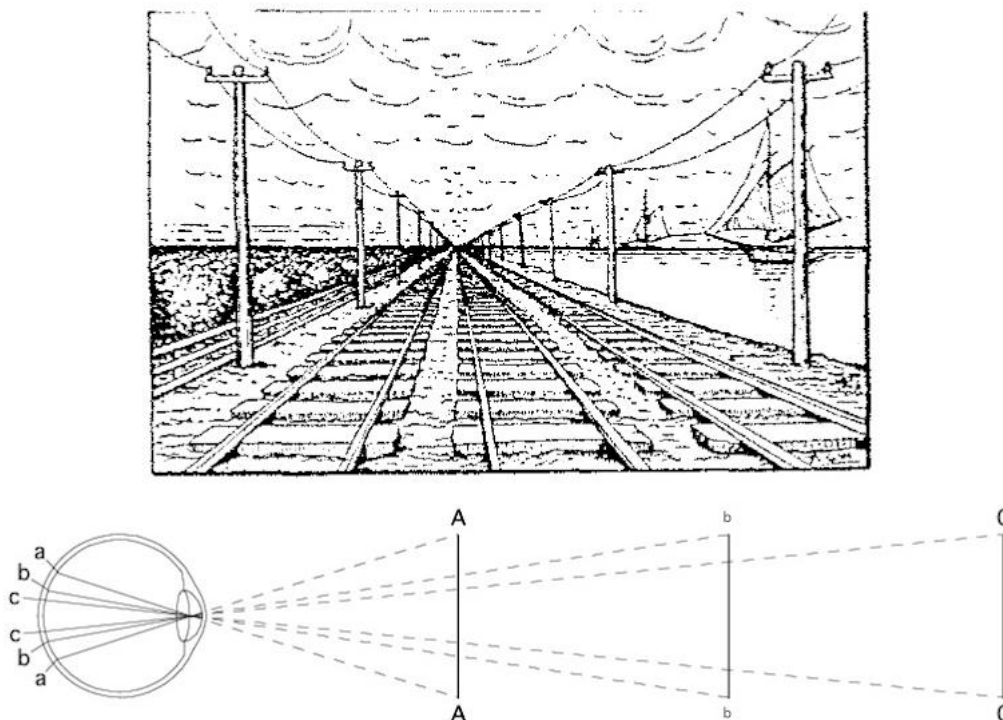

Fig. 17

The imaginary line from the horizon to the eye is almost horizontal, because experience shows that the horizon is in

Eye level, because it is formed in the eye of the observer. If the plane remains horizontal, as in sketch 5.10 above, the perspective reduction of the distance between eye level and the earth's surface with increasing distance must move the image of the earth's surface, in the above case the rails, masts, bushes, the sea surface and ships, ever closer to the optical axis, i.e. cause them to curve concavely. The optical reduction of the objects and surfaces is incorporated into the horizon line at a visual angle of 1 arc second.

The schematic sketch of the eye and the imaginary rays indicate the first telegraph pole at A, the second at B and the third at C. Accordingly smaller

the image impressions on the retina of the eye until they are below the perception limit.

The hull of the third ship on the horizon becomes invisible as it merges with the horizon line, and only the top of the mast remains visible. Optical phenomena require careful interpretation in accordance with the laws of optics. This is why astronomers in particular, and even more so astrophysicists, must use their knowledge and practical experience from the field of optics when interpreting and assessing the images they see or photograph. They should not tolerate the horizon being used as popular "proof" of the shape of a full sphere, nor the photographed image of the Earth's surface from the moon. These images in particular were seen as triumphant proof of the now proven correctness of the theoretical concept of the universe that is generally held by scientists today.

The layman may react in this way to this optical phenomenon because he takes what he sees as reality. The scientifically trained researcher is given the task of critically examining the image of the earth using the known optical principles and laws. See the statements of the physicist W. Braun on this topic.

### Geometry and the Morrow measurement

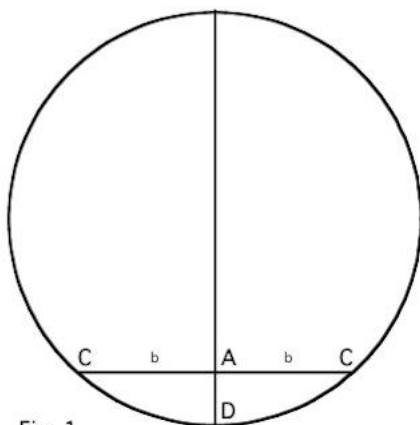

Fig. 1

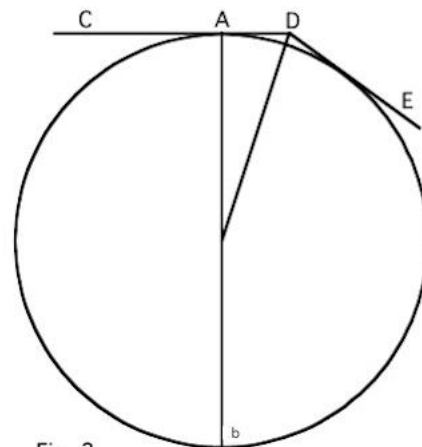
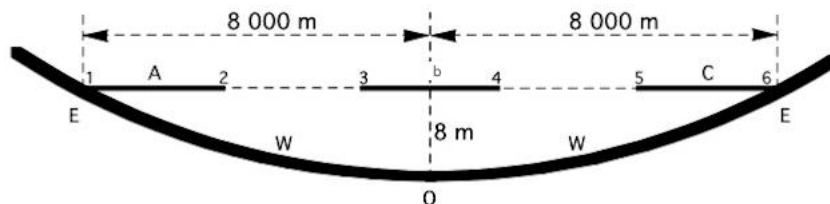

Fig. 2

Fig. 18

Fig. 1 shows the straight line from C to C where it rests on the earth's surface. The line A D indicates the vertical plumb line and the difference to the concave earth's surface. Fig. 2 shows the drawing of a straight line C D or D E. The diameter A B and the radius at D indicate the vertical plumb line, which plays an important role in the measurement.



Drawing No. 8

0-Location of the beginning of the straight line next to a water surface of the Earth W' water surface

E- Endpoints of the straight line at a distance of 8 kilometers A B C " = sections of the straight lines

1-8 —• beginning and end of the sections

Fig. 19

Figure 19 shows the application of a straight line to the hollow sphere shape of the earth. The differences to be measured here are in the range of meters and therefore lead to absolutely clear measurement results, as the critical presentation and theoretical review of this measurement by the physicist W. Braun in his work presented here, Die Klassische 50

Geodesy by U.G.Morrow in 1897".

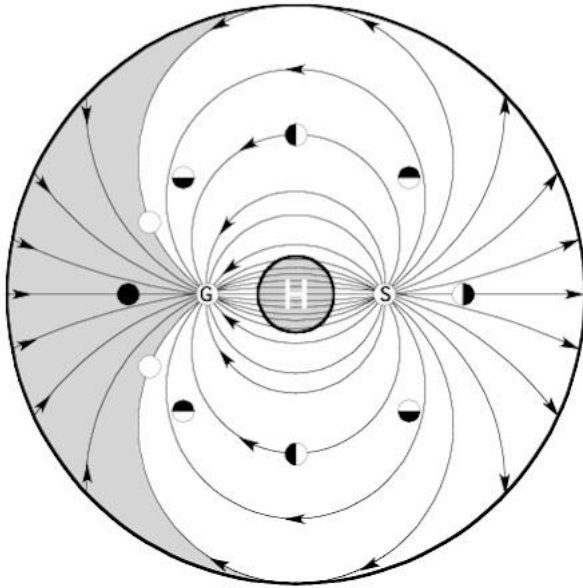

Fig. 20 The Inner World Power Image

### Professor Sexl and his students at the University of Vienna

In order to show the reader right at the beginning that he is not wasting his time on a pipe dream, we first read a treatise by an excellent university lecturer, Professor Dr. Roman U. Sexl from the Institute for Theoretical Physics at the University of Vienna.

One of his students sent him a paper by a German geophysicist on the hollow-sphere model of the cosmos, translated into English. Did Professor Sexl know that this world model in the USA proved to be identical to reality as a result of a measurement on the earth's surface, which was then presented? Was that why he became interested in this model of the world?

In any case, he used it to challenge his students to refute this hollow sphere model of the cosmos as absurd.

However, to the students' great surprise, the mathematical irrefutability of the Earth's hollow sphere model proved itself and Professor Sexl published his didactic experiences on the intertwining of philosophical and mathematical problems and described the world model in the form of the Earth's hollow sphere (today called the Celestro Centric System) as one of the most enchanting alternative world views!

Professor Sexl obtained all available literature that was available in the USA and Germany and had the electrically powered model built in Germany, approximately 0.80 meters in diameter, demonstrated to him, which represents day and night, the seasons, the phases of the moon, the eclipses of the sun and moon, and the flight of satellites.

From him, the proponents of the inner world theory received the extremely important confirmation that the hollow sphere model of the cosmos, when correctly transformed from the model of the solid sphere Earth, is mathematically absolutely irrefutable.

Read the Festschrift by Prof. Sexl, excerpts of which are reproduced here, which he gave to his friend Prof. Dr. Phil. nat. Wilfried Kuhn (1983), Director of the Institute for Physics Education at the Justus Liebig University in Giessen. (Note: At that time, Professor Sexl was still using the old name "hollow world theory" coined by Johannes Lang, which has since been replaced by the term "inner world theory".

## The hollow world theory

by Roman U. Sexl, lecture at the general meeting of the German Association for the Promotion of Mathematical and Scientific Education, 1983 in Tübingen.

(Printed in MNU)

Dedicated to my colleague and friend Wilfried Kuhn on his 60th birthday.

The hollow earth theory is a physical theory that was put forward in the USA in the 19th century and in Germany in the 20th century. According to it, the earth is a hollow sphere in whose interior we live and where the stars, sun and moon are also located. This theory sounds completely absurd at first and one thinks that it can be refuted with a few short arguments. However, it soon becomes apparent that even the most detailed considerations encounter difficulties and that an experimental refutation of this theory is in principle impossible, assuming suitable basic laws of physics. This opens up interesting aspects regarding the cross-connection between physics and philosophy, the question of the correctness of the physical world view and the provability of theories through experiments.

## The Magic of the Hollow World (today: Inner World Cosmos)

One of the most beautiful reasons for studying physics is the combination of exact mathematical representation with deep philosophical questions, with questions about the origin, history, shape and fate of the universe.

In cosmology, the separation between the two "cultures" described by C.P. Snow (1) or between the "two mental states" that Robert Musil characterizes in his "Man Without Qualities" as follows is abolished:

"There are, in reality, two mentalities which not only fight each other, but which, what is worse, usually coexist without exchanging a word, except to assure each other that both are desirable, each in its own place. The one is content with being precise and sticking to the facts; the other is not content with that, but always looks at the whole and derives its knowledge from so-called eternal and great truths. The one gains in success, and the other in scope and dignity. It is clear that a pessimist could also say that the results of the one are worthless and those of the other are not true. For what do you do on the Judgment Day, when human works are weighed, with three treatises on formic acid, even if there were thirty of them?! On the other hand, what do you know about the Judgment Day if you do not even know what all can become of formic acid by then?" (2), p. 248

"The combination of exact mathematical and experimental analyses with epistemological, scientific, philosophical, historical, humorous and essential observations of this world is necessary if physics is not to present itself to the learner as a science from which nothing remarkable emerges," as Musil calls the first chapter of his book. How necessary the intertwining of different worlds is for a truly profound understanding of physics will be shown here using one of the most curious and also most enchanting "alternative world views," the hollow earth theory.

Prof. Sexl then writes what his informant M. Gardner, USA, told him about the activities of the American doctor Dr. Cyrus R. Teed.

Dr. Teed was a devout practicing Christian who was informed by the Bible's theocentric world model and could not agree that God's creation was the accidental product of cosmic catastrophes, as was widely believed by 19th century philosophers.

Dr. Teed conducted optical experiments on a straight canal, several kilometers long, and determined that either the light beam could not be straight or, in addition, that the surface of the earth must be concave (hollow-round), although astronomers believed they had determined the opposite.

Teed gave lectures and gathered around him a religiously motivated community that was willing to provide God with scientific proof that God's creation of heaven and earth looks like it is described in the Bible, namely as a "cellular cosmos." The community raised money, obtained land in Florida from a German immigrant named Kofler, and sought a surveyor who could plan and take a measurement of the earth's surface.

to determine whether the Earth's surface has a convex or concave curvature in order to be able to conclude whether the Earth's body is a solid sphere or a hollow sphere.

Never before in the history of mankind had such a measurement been made, and geodesy scientists did not consider such a measurement necessary because the optical image of the horizon seemed to prove that the Earth could only be a solid sphere.

The person who carried out this measurement on behalf of Dr. Teed was Professor U. G. Morrow.

Read the report of the measurement in 1897. Unfortunately, M. Gardner probably did not report this measurement to Professor Sexl or was unable to provide the scientific documents.

Professor Roman Sexl does not mention this measurement and only dealt with this hollow sphere model of the Earth based on theoretical physics.

Geodesy and astronomy scientists took no notice of this measurement. This is incomprehensible, because this measurement placed their field of knowledge on a new foundation; the planets and stars were no longer theoretically in the infinite expanse of space, but relatively very close at an altitude of around six thousand kilometers.

This scientific problem became a psychological problem immediately after the results were announced that the surface of the earth is concave, i.e. hollow; because what was not allowed to be, could not be.

And so something incredible happened. The book by Dr. R. Teed and U. G. Morrow, "The Cellular Cosmogony," in which Morrow's measurements were scientifically documented in detail, "disappeared" from libraries so completely that it could not be found in any university library today that no professor or student can find it in any library. After an intensive search, a librarian found this book in a single, albeit very prestigious library, the Library of Congress in the USA, and nowhere else in the world. However, it can still occasionally be found in second-hand books in the USA and has been reprinted since the 1970s.

Unfortunately, this meant that the students could not read the original.

Professor Sexl relied primarily on the German literature of Johannes Lang, who changed the very apt term "Cellular Cosmogony" to the hollow earth theory because the earth is a hollow sphere. Unfortunately, the important content and the celestial sphere at the center were thereby excluded from the concept.

While in the USA the religious community "Koreschan Unity" lived in honor of God and his creation and after Dr. C. R. Teed hardly anything scientific happened anymore with regard to measurement concerning the world view, in the twenties and thirties of the twentieth century many people in the USA under the leadership of U. G. Morrow and in Germany occupied themselves with this view of the world.

The writer Johannes Lang in particular found a large readership because he was able to present scientific problems in a logical and understandable way and to find a solution by developing the so-called hollow earth theory. Lang's successful period of public influence was in the 1930s. However, because he rejected the Hitler system and corresponded with the Americans, and these ideas were suspect to the National Socialists because they came from America, Lang was observed, as was his colleague Peter Bender, and was seen as politically unreliable.

After Hitler's deputy Rudolf Hess flew to England in 1942, Lang and Bender were sent to a concentration camp. While Lang was released after a short time, Peter Bender had difficulty getting out because he was found in possession of material and correspondence with the American Koreschan Unity, namely with Hedwig Michel, who came from a Jewish family in Frankfurt. Peter Bender died in the concentration camp. The National Socialists rejected Lang's hollow earth theory and never tried to establish contact with Lang, apart from imprisoning him.

This is to clarify some sensational statements, as if Hitler's people had any benefit from the knowledge of the hollow earth theory. (From oral reports by Johann Lang and my own experiences)

After this interlude and a partial expansion of the information about the origin of the sky-centric world view, here called the hollow world, Professor Sexl began to present the hollow world theory to his students. However, they became very thoughtful when they were asked to comment on this alternative world curiosity based on their knowledge of physics in order to refute the statements of the so-called hollow world theory.

Professor Sexl further reports:

"The unanimous rejection is soon justified by a number of recurring objections. The following problems are usually raised:

-How do day and night arise?

-How is the horizon created?

-How do you explain gravity?

-How can the smaller sun produce the necessary energy?

-What happened during the moon flight?

Don't the images of the Earth from space clearly show a solid sphere?

These are the most important of the recurring objections that are discussed and refuted in the lecture using a slightly modified form of the hollow earth theory. (The systematic nature of these deviations is discussed in section 3). As far as the objections relate to the propagation of light and the creation of day and night, they can easily be refuted by referring to the illustrations. They show that light rays propagate in circles that always pass through the center of the earth (mathematical requirement). The speed of light is not constant, but decreases quadratically towards the center of the earth, so that this point in the world is never reached by light. The law of light propagation also explains the formation of the horizon and shows why the earth appears to be a solid sphere when seen from space. This optical illusion can also be traced back to the laws of light propagation.

All questions regarding the movement of bodies in the hollow earth theory can also be easily analyzed. Newton's equations of motion turn out not to be entirely correct. Rather, these equations should read:

$$m \left( x - \frac{4rx}{r} - \frac{2rx}{r} + \frac{6r^2x}{r^2} = \frac{r^2}{R^2} F \right) \quad (1) \quad \text{Where } r = |x| \text{ is the distance of the considered point from the center of the earth and } R = 6370 \text{ km is the radius of the earth. In the case of gravity, the corresponding force expression for the gravitational field of the earth is, for example, as in formula (2)}$$
$$F = \frac{mMG}{R^4} rx \quad (2)$$

Of course, it is not immediately obvious that the newly formulated "Lang's equations of motion" actually correctly represent the orbits of celestial bodies and can also describe the movement of terrestrial objects. However, students are usually willing to accept that the calculation of the orbit shapes, which can easily be carried out with the help of a computer, actually leads to results that agree with the observations.

But what about moon rockets?

Note: When calculating the size of celestial bodies, Professor Sexl assumes that light is curved in circular orbits. This is an assumption, a theory at best, and has not been proven in practice. The sizes of celestial bodies calculated on the basis of such an assumption are too small, so that one must request a correction of the calculations with the help of the branch of science morphology. In his calculations, Professor Sexl arrives at a diameter of 1 km for the moon. The distance from the center of the earth is said to be around 3000 km. Previous calculations carried out by Lang and others based on mathematical assumptions such as the circle, for example, produced equally improbable results that are not in line with the shapes of nature. Remember that this is a cellular cosmos and the laws of morphology apply. This is where the typical problems of pure mathematics arise, which cannot be corrected because the mathematically recorded object cannot be examined directly, be it because it is too large, too small, or too far away.

The model built by the sky-centric worldview took morphology into account, assuming that the moon had a diameter of about 200 km. This would give a circumference of the lunar sphere of over 600 km. A respectable size that fits well with everything that was shown of the moon on television and in pictures and what the astronauts said very emotionally during expeditions to the moon. NASA had prepared a lunar survey in that an odometer (or mile counter) was built into the lunar car used. Since this did not provide the expected information, the relatively simple technical device was declared defective. Here there was a real chance of measuring the size of the moon. But the data is certainly still in the archives and will one day be accessible. The values given today, in 2001, do not match the statements made by the astronauts during their stay on the moon.

Read the chapter about the moon landings.

Professor Sexl solved the problem of the size of the moon in a curious way using the theory of relativity and mathematics: If the moon were only 1 km across, wouldn't the lunar module and the human appear oversized? But that contradicts the images we saw; everything looks normal here.

If one assumes that the bodies shrink in size as they approach the center, this relationship is mathematically expressed in the expression

$$L = L_0 (r^2/R^2) \quad (3)$$

where  $L_0$  means the size of the object on the Earth's surface.

This mathematical law is surprising at first, but there are similar phenomena in other areas of physics. For example, objects can expand due to the influence of temperature or shrink due to the influence of speed, as the theory of relativity teaches. In any case, the remarkable formula (3) can now explain why people and objects on the moon appeared so small; if the moon were 1 km in size, a person would have been only 3.4 cm tall.

Note: This is an argument that can be made using the theory of relativity, i.e. theoretical physics. In any case, there is no mathematical argument that this could be the case.

It would have been much better if the moon had been measured according to scientific geometry, but the time and equipment were lacking.

Professor Sexl continues: This dialogue, in which all the students' objections to the new world view can be refuted, usually lasts about one to two hours. The mood in the lecture hall fluctuates between resignation and indignation. Years of studying physics do not allow one to rule out such a seemingly senseless claim that the earth is a hollow body and encloses what we experience as the universe on empirical grounds in just a few minutes. Everything that previously appeared to be proof of the Copernican theory now becomes proof of the hollow spherical earth as the form of the cosmos. If it is true that the usual world view of physics has been experimentally proven, then the same experiments have now also proven the hollow earth theory.

The empirical world view, which has become second nature to the physics student through his work in practical courses and laboratories, begins to falter. If theories are based on experiments and follow from experiments, then the hollow earth theory suddenly follows from the same experiment.

Editor's note: It is precisely at this point in the study that the connection between the mathematical model and reality becomes clear, because mathematics describes reality according to its method.

From these experiences, the dualistic world model was born: from the theoretical part of the calculation model and the biological-material part of reality.

It began with the application of the so-called transformation of the reciprocal radii. Through this operation, the mathematician relates the space outside a sphere to the space inside this sphere, thought of as a hollow sphere. This made mathematical development possible by Professor Sexl and he developed the following laws. He goes on to say:

To arrive at the laws (1,2,3), it is only necessary to carry out the transformations of the inverse radii in all known laws of physics,

$$r_H * r_K = R^2 \quad (5)$$

where  $r_{H,K}$  are the distances from the center of the earth in the hollow sphere earth or in the Copernican world view. In this way, one world view can be transformed into the other. If the Copernican world view is experimentally irrefutable, this also applies to the model of the hollow earth theory. The change in topology caused by the transformation (5) can also be corrected by the boundary condition (4) that we have formulated here for the wave functions.

$$\phi(x) = \phi(-x) \text{ for } x \rightarrow \infty \quad (4)$$

The mystery is solved and the hollow earth now appears as merely a mathematically equivalent form of the Copernican world view. Both can be transformed into one another.

During the lecture, everyone sits back in their seats, satisfied. But the next problem immediately arises: the usual world view of physics is based on experiments. The same experiments also support the hollow sphere model of the world. No physicist can therefore refute the view that the earth is a hollow body on whose inner surface people live. Should this view be taught in schools as an equal in the future, or if not, why not? Should the hollow world view become the new school material as an alternative world view that is more in line with the Bible than the current world view?

Fundamental problems of the theory of science become topical for the physics student. The professional honor is at stake, and the

Listener compiled a list of arguments against the hollow earth theory.

In 1962, a book by the director of the Bochum Observatory, Joachim Herrmann, "The False World View" was published, which contains a critical study of astrology, the theory of the world ice, the hollow earth theory, the habitability of the sun, flying saucers and other astronomical false doctrines. Herrmann says: "Of course, space travel in a hollow spherical earth would be completely unthinkable. The moment the first rockets can leave the earth not only for gliding flights into the atmosphere, but also for hundreds of thousands or millions of kilometers, the verdict on the idea of a hollow spherical earth would be more than final, and above all for those who are not at all versed in astronomy.

Millions have seen the small artificial moons in the sky with their own eyes. The time of the hollow earth theory is finally over. (p. 116)"

Refuting the alternative worldview is not that simple. As we have seen, there can be no refutation in the sense of an experimental counter-proof (or it would also refute the usual worldview).

This problem is also important because it is typical of many debates about the "alternative worldviews" that are often proposed by "outsiders of science".

As a preliminary remark, it should first be noted that the systematic, mathematical treatment through the transformation of the inverse radii is not typical for the emergence of such an alternative world view. Experimental evidence for the new views is usually sought. Within the rational construction of alternative world views given here, this represents an incomplete transformation of the standard world view.

The transformation equations (5) are not applied to all phenomena, but usually a part of the old physics is adopted unchanged.

Now back to the scientific-theoretical objections to the model of a hollow spherical earth.

What objections are most often raised in the lecture against the false "world view"? After it has been clarified that there can be no experimental refutations, the reasons for preferring the Copernican world view are most often given:

- a) Simplicity
- b) clarity
- c) freedom of choice

To justify a), it is argued that the laws of motion (1) in the hollow earth theory are far more complicated than Newton's laws. However, of two theories that explain the same facts, the simpler one is preferable. This argument certainly contains a grain of truth, but it is also problematic. For example, to explain the deviation of Mercury's orbit from Newton's ellipse, one could just as well use a simple modification of the  $1/r^2$  law by changing the exponent instead of the complicated theory of relativity. Wouldn't this argument then also speak in favor of replacing the general theory of relativity with simpler, more understandable theories?

The main argument for the Copernican theory is its visual appeal. In this theory, the theoretical explanations correspond much more directly to what we see with our eyes than is the case in the hollow earth theory.

But is it really so obvious that the sun is a huge glowing ball of gas? Wouldn't a much smaller moon give a much better impression of the starry night sky?

With regard to freedom from arbitrariness, it is argued that instead of the transformation, one could just as well substitute many other transformations that offer alternatives to our standard world view. In this way, one could also construct a theory with a flat earth. Couldn't a proponent of the hollow earth theory even think, conversely, that the Copernican world view is just one of many arbitrary transformations of the hollow earth? These arguments and answers already show the uncertainty that affects the physicist who is not trained in the theory of science when he gets involved in questions that concern the foundations of his field but cannot simply be decided experimentally. It also shows the need for a scientific and historical foundation for the subject, which Wilfried Kuhn often emphasizes and which is also expressed in his books.

Fundamental to every theory are the symmetry groups it contains. These symmetry groups make it possible to link results obtained in different systems, by different observers or at different times. The numerous connections resulting from the group structure are among the 2003 Helmut I Diehl 56



most important predictions of the theory. These predictions are particularly easy to falsify because of their rigor and conciseness.

The history of the theory of relativity provides an instructive example of these considerations. In the ether theories, there was no specific point in space, but there was a specific speed, i.e. a specific reference system, namely that in which the ether rests. The extent to which the ether wind, which was supposed to be caused by the movement of the earth through the ether, influenced the experimental results was a question that had to be answered primarily experimentally. Therefore, countless experiments on various bases attempted to determine the movement of the earth through the ether. The negative outcome of all these experiments could always be interpreted without contradiction in the ether theory by a suitable modification of the basic equations, for example by incorporating the Lorentz contraction. However, every positive result of these experiments could also have found a satisfactory explanation within the ether theory.

While ether theories can therefore only be recognized as false with difficulty, the situation in the special theory of relativity is completely different. Here the ether is excluded as an element of theory formation and a much larger symmetry group, the Lorentz group, characterizes the structure of the theory. It now follows necessarily that no experiment can determine the movement of the earth through the non-existent ether, and it follows just as necessarily that the outcome of every experiment must therefore be independent of the speed at which the laboratory in question moves. Here the negative outcome of all experiments that have set themselves the goal of determining the movement of the earth in the ether now finds a convincing explanation. However, a positive outcome of the experiments would be completely incompatible with the theory and would mean a falsification of its foundations. Therefore, the theory of relativity is superior to the ether theory from a scientific point of view. This is at least one possible point of view that can describe the "dynamics of theories" as the historical replacement of different physical theories in this case.

The hollow earth theory is quite analogous: In it there is a special point in space that prevents any spatial symmetry group. This also applies to the Aristotelian (geocentric) world view, in which the center of the earth was, however, special (a solid sphere). With the "Copernican revolution" the transition to a theory with a larger symmetry group and thus an increased possibility of falsification takes place.

We have presented these historical and scientific-theoretical considerations here using Popper's philosophy as an example. In a similar way, the statements and arguments of other scientific theorists can be applied and tested on the hollow earth theory and similar cases. The profound emotional experience that the empirical irrefutability of the hollow earth theory offers many physics students is always in the background as the driving motive for further studies. This shows once again how a didactically appropriately selected starting point can be an essential and specific motive for dealing with new areas and unfamiliar arguments. Physics, didactics, history and scientific theory merge into one unit.

The unabridged lecture is available to anyone interested.

Concluding remarks on Professor Sexl's lecture

Compare the statements of the director of the Bochum public observatory, the astronomer Herrmann, with the findings of Professor Sexl, who has a confident command of his subject and clearly states that the hollow earth theory cannot be refuted with phrases or with the means of mathematics. He even shows an important connection between the two theories by explaining that both representations, the solid spherical earth and the hollow spherical earth, are so closely linked by transformation that if one representation is proven wrong, the other is also wrong. It is just like looking at a person or an object in a mirror. If you prove that the person or object is wrong, then of course the reflection is also wrong.

Is the sky-centric world view (hollow earth theory) with its hollow spherical shape the mirror image of the Copernican world view, with a solid spherical earth, or is it the other way around, that the biological structure of the hollow spherical earth has its mathematical mirror image in the excellent calculation model of the Copernican, Kepler and Newtonian representations? What did the thousands of scientists want when they explored the cosmos? They were concerned with the mathematical description of the reality of the world using the means of mathematics. If all physics experiments confirm the mathematical model of the cosmos and the biological model of the cosmos, then we have here the synthesis of the two world view models that grow together into a dualistic model. This discovery by the physicist Wolfgang Braun, who scientifically accompanies or presents important parts of this book, created a scientific breakthrough, so that when Professor Sexl read W. Braun's article published in the USA, he decided to present the then so-called hollow earth theory to his students so that they could test their knowledge and also experience the limits of mathematics and theoretical physics.

Even today, as always, it is true that the experiment is the decisive action, that measurements are taken wherever possible. The result of the experiment, however, is the basis for further research and cannot be refuted by any theory; because where clear facts are available, the desired goal has been achieved, namely to recognize reality.

The presentation of the most important experiment of the last three thousand years is the main topic of this book and at the same time the most important part. This result proves that the hollow spherical shape of the earth with its biological content, including the sun, moon and stars in the sky, is a proven fact. The excellent calculation model of Copernicus, Kepler, Newton and all the many researchers who founded this model remains what it always was, the correct mathematical reflection of reality.

Literature for the lecture by R.U. Sexl:

(1) P. Snow: The Two Cultures, Stuttgart, Klett 1967.

(2) R. Musil, The Man Without Qualities, Reinbek near Hamburg: Rowohlt 1960.

## The dualistic worldview model

One unit: the computational model and the biological model.

The physicist W. Braun writes: "Models are thinking aids for scientists and make it possible to answer certain questions and obtain certain statements.

The world view model according to Copernicus, Kepler and Newton cannot make any definite statements on the questions of God, the creator of the world and heaven. This became a great deficiency, indeed a disaster for people's religiosity, for philosophy, for the understanding of the meaning of the world and the meaning of human life in particular.

The last four hundred years of human history have brought enormous advances in technology and material progress such as never before in the foreseeable past.

The loss of faith in the Creator God and the rejection of the world view of faith that taught that the Creator God was high up on his throne in heaven caused the decline of ethics in our culture. Failure to follow the Ten Commandments, which demand a natural minimum of good behavior from people without which human communities cannot thrive in prosperity, led to resentment and envy.

The consequences of this were ideological substitute religions that fanaticized people and turned them into murderous enemies. With the help of technology and the many scientific achievements, the increasing evil of the rulers and their servants meant that more people were killed, raped and driven away than ever before in recent history.

These are the devastating consequences of a misunderstood worldview model that we believe to be reality because it was taught in school and presented to the public.

Now that the exemplary nature of this mathematical model has been recognized by the world again and many people suspect that the cosmos, or at least the earth, is something biological, the time seems to have come for people to be ready to abandon the idea that the world is a primitive machine. People have become sensitive to the biological, to the cosmos, as something living. This new feeling is expressed particularly strongly in the effort to protect and preserve the environment as a basis for life.

The measurement of the earth's surface by Prof. U. G. Morrow and Dr. C. Teed in 1897 in Florida/USA proved that the entire cosmos visible to us is enclosed by the earth's shell; the earth's surface proved to be hollow and curved (concave) during this measurement, which means that the entire universe, with its dimensions that were unimaginable in the Copernican view, is located in the inner cosmic space that is enclosed by the earth's shell. The starry sky we see is in reality a sphere in the center of the earth's interior, where the fixed stars have their fixed place. The sun and the moon are much smaller than the sizes calculated on the basis of assumptions.

Are these statements not in irreconcilable contradiction to everything that science has worked out and recognized in tough struggles over the course of centuries? Are we not confronting two worldviews that are just as incompatible as fire and water? The organic, natural worldview of the inner cosmos versus the scientific worldview named after Copernicus, based on mathematics and physics? Doesn't one exclude the other?

What makes both appear so contradictory, here the hollow spherical shell with the inner cosmos and there the solid spherical earth with the outer cosmos, is so closely connected by mathematical transformation that no world model can be mathematically refuted by the other. The contradictions disappear when one uses the so-called "transformation by reciprocal radii". Through this operation, the mathematician brings the outer space of a solid sphere with the

possible interior of a hollow sphere. By applying this transformation to the Copernican world view, an opposite world view becomes possible, which corresponds to the organic, natural image of the inner cosmos and to the world view of the Bible. The laws and relationships that Kepler and Newton found in their models remain intact. But the enormous distances of billions of light years, the infinite emptiness and the apparent meaninglessness have disappeared. One recognizes the celestial sphere in the center of the inner world and understands that through this transformation the straight light rays of the Copernican view become curved rays. This then results in the fact that the sphere of fixed stars in the center of the inner world not only appears optically enlarged due to the spread of light in the form of curved light rays, but becomes an optical vault of heaven in which the surfaces of the sky and the light disks of the sun and moon also appear enlarged towards the horizon. After the transformation, the speed of light assumed to be constant throughout space in the Copernican theory becomes a speed of light that decreases sharply towards the center. This explains, for example, that the travel time of a light beam from the sun to the earth's surface is about 8 minutes, even if the distance is much smaller than according to the Copernican theory. A probe to Mars is known to take several months. Although the distance to be covered according to the world view of the inner cosmos is much smaller than according to the Copernican world view, after the transformation the speeds of rockets also turn out to be much smaller than the mathematicians base their calculations on. So there is no contradiction here either.

These were some examples to show that the organic, natural world view of the inner cosmos is very current and timely, and that it points far beyond our time into the future. There are therefore no truly irreconcilable opposites to the Copernican, Kepler, and Newtonian world models in the sense of theoretical physics and mathematics, and in this sense the opposing world view does not represent a break with the previous one. It is an astonishing addition, because the mathematical describes the organic as a computational model, and the organic gives the mathematical the quality of the biological.

Kepler's and Newton's laws of planetary motion and gravitation remain valid in the organic, natural world view, only here they are found in a transformed form.

The Copernican world view is therefore not reality, but a model based only on mathematics and physics. The whole of reality results from a combination of both world view models. The bridge from model to model is formed by the transformation mentioned above.

But only those who seek the truth can cross this bridge. But not everyone can find it and accept it."

## The Curved Space Metric of the Inner World I

W. Braun, physicist

### The law of inertia

The beginning of today's experimental natural sciences lies in the middle of the 16th century. With the work of the Italian physicist Galileo (1564-1642), the final turning away from the mostly purely philosophical approach of ancient Greece, which was unproductive for physics, towards the experimental questioning of nature took place. Galileo was a staunch opponent of Aristotle, while he greatly admired Archimedes.

His investigations were mainly concerned with falling motion and the motion of bodies on inclined planes. He defined the state of motion of uniformly accelerated motion and recognized that the form of motion is causally linked to forces. (Newton was the first to recognize that it must be a force that is constant over time that causes this uniformly accelerated motion.)

Another crucial finding that emerged more or less incidentally during his research is the law of inertia. We want to describe and examine this law in detail. In today's formulation, this law states:

A body that is not acted upon by an external force remains in a state of rest or uniform motion in a straight line. For example, a billiard ball on a flat surface can only be in two states if no force acts on it: either it is at rest or it rolls straight ahead at a uniform speed.

A steel ball on a smooth surface of ice rolls a long way, say 1000 m, in a straight line at a constant speed. In reality, the speed is of course not exactly constant, as the inevitable friction slows it down slightly and eventually brings it to a standstill. At least in your mind, you can idealize this experiment by completely eliminating all friction. In this imaginary case, the ball would then roll on forever at a constant speed.

We now know that the Earth's surface is spherical (whether the curvature is hollow or completely round is an open question for now).

Our steel ball, freed from all friction, will therefore roll around the earth forever, assuming that the law of inertia is correct. On the small ice surface of a lake, one could speak of rectilinear motion, since the curvature of the earth is not noticeable at short distances. However, when the experiment is expanded to include the dimensions of the entire earth's surface, which can already be described as cosmic, the trajectory is curved in the shape of an arc, and is therefore no longer rectilinear, as the law of inertia claims. So is the law not correct after all?

On the other hand, the law of inertia seems to be correct, since there is no reason why the ball should come to rest on its frictionless trajectory. There seems to be a contradiction here. But it is only apparent, since the law of inertia applies under the express condition that no external force acts on the body. But in our thought experiment we have only eliminated the frictional force. We have not thought about gravity. But it is gravity that permanently binds our ball to the earth's surface. It is important to note that the law of inertia states two properties of motion:

1. The straight path.
2. The uniform speed, provided that no external force acts. Point 2 is guaranteed because the frictional force has been eliminated. Point 1, however, is not fulfilled because the movement is not free of forces due to gravity.

Therefore, the path is not straight, but curved in a circular arc. In this case, however, the law of inertia is only partially applicable. However, there is no contradiction. How would the path change if it were possible to eliminate gravity, at least in our minds?

To find the answer to this very crucial question, let us use some thought experiments to get us on the right track: A stone thrown horizontally does not fly far.

Gravity catches it and pulls it to the ground. After, say, 10 meters, it hits the ground. A bullet has a much greater speed when it leaves the barrel. It can fly much further in a horizontal direction, about 500 meters, before gravity pulls it to the ground.

From a purely formal perspective, one can say: the slow stone is subject to gravity to a greater extent than the fast bullet.

A projectile travelling at the highest speed would then no longer be affected by gravity at all. We would be very interested in the trajectory of such a projectile, because its movement would be ideally free of forces, friction would be eliminated through idealization, and gravity would be eliminated through its high speed. The principle of inertia would then apply without restriction to such ideally free movements.

Thanks to the findings of physics, we now have such extremely fast projectiles at our disposal, namely light corpuscles. According to the corpuscle theory, light consists of tiny particles, the so-called light corpuscles or light quanta. These are thrown out by every light source, be it a candle, a spotlight or a LASER beam device.

They shoot through space at the unimaginable speed of 300,000 km per second. Because of their great speed, they are practically unaffected by the Earth's gravity. They move as if gravity did not exist.

This means that the movement of the light particles is ideally free of forces. According to the principle of inertia, their path should be exactly straight and travel at a uniform speed.

If the principle of inertia applies throughout the cosmos, then the statement that light propagates in a straight line and at a constant speed throughout the cosmos is also correct. This statement has been a self-evident, tacit assumption that has never been questioned since the beginning of human research into nature. "Light propagates in a straight line."

This is still a fundamental law of optics today. The statement is based quite simply on the practical experience of everyday life. "You can see that the light beam is straight. But you forget that the length of the beams is short in these observations. Any deviations from straightness cannot be recognized. But even the slightest curvature could add up to enormous deviations at cosmic distances. The historical development of the statement about the straight propagation of light in the cosmos did not lead to the Galilean principle of inertia, as described above.

Rather, the hypothesis of the straight propagation of light is already contained in the law of inertia. If one were to ask Galileo or one of his successors as representatives of modern science how the term "straightness" is defined, he would have to answer: "Straightness is defined by the path that the light ray travels in free space." Modern science does not actually know any other definition of straightness. This is also the deeper reason why an experimental verification of the straight propagation of light was never considered and is still considered absurd by modern science today; because the only verification of the path of a light ray in space would be to compare it with a straight line.

However, since this is defined by the propagation of light, and modern science has no other measuring line available, the linear propagation of light remains an unproven hypothesis. It was very obvious that Galileo was also looking for force-free movement on the line defined by the light ray. According to earthly experiments (e.g. billiard balls), force-free bodies follow the same path as the light ray. Any deviation that may exist could easily escape observation.

The narrow range of earthly experience suggests that the force-free path of a body and the path of a light beam are identical. Both are described as being straight-line based on visual appearance. This raises the crucial question: does this identity remain the same in cosmic dimensions, or are there differences there?" Of course, this question has never been directly tested experimentally, as such an experiment is not feasible. However, there are countless indirect indications that justify or even demand this transfer of earthly experience to cosmic areas. The Kepler-Newton system of celestial mechanics is based on this basic assumption, which is usually not even stated, that the force-free path of a celestial body in space and the path of a light beam coincide. Both are described as being straight-line by definition (by definition).

Due to the completeness and usefulness of this astronomical system in its practical application, there can be no doubt that this basic assumption is sensible and correct. Since this crucial connection is never considered worth mentioning by modern science, but is taken for granted, it is particularly highlighted here and formulated with all emphasis:

The trajectory of the light beam and the trajectory of the force-free bodies are identical.

This statement is an irrefutably correct result of centuries of astronomical research. The only thing that is in question is the shape of this orbit. Today, as in the past, it is described as being straight, and is even used to define straightness.

However, experimental support is completely lacking!

After these considerations, let us return to our thought experiment with the steel ball rolling smoothly. How will it move when it is no longer subject to the Earth's gravity, about 61

then if it is thrown off at a very high speed? According to the Kepler-Newton theory, it would lift off the surface of the earth following the light beam and escape into space on a straight path, as shown in Figure 22a. This result is certainly to be expected, due to the internal closure of this system, which has shown its preservation up to the time of space travel in recent times.

However, if the earth's shell is concave (hollow) and the light beam is therefore curved, the trajectory of the steel ball is also curved. According to this system, the ball lifts off from the earth's shell after a short distance and rises into space on a curved trajectory (Figure 22b). Any theory that claims centrifugal adhesion to the earth's shell would be absurd, as it would contradict all experimental experience in its diverse and complex connections.

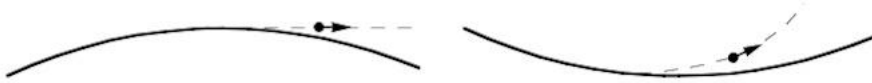

Fig. 22

a) convex curvature of the earth and b) concave curvature of the earth

Figure 22 shows a body that moves tangentially to the Earth's surface at very high speed without any force and lifts itself off the Earth's surface.

### The metric of space

Straightness appears a third time in the Kepler-Newton theory. According to Newton's findings, all masses attract each other. This mysterious attraction is called gravitational force. The mass of the sun binds the planets to itself through its gravitational effect and forces them into closed orbits. The field lines of the gravitational force field are again straight lines, which extend radially from the center of mass into space.

This straightness is also never particularly emphasized. Rather, it is tacitly taken for granted, since it is the simplest and most obvious assumption. After our previous considerations, in the course of which the uncertainty in the definition of straightness became clear, a more cautious and general formulation would be appropriate here too.

Instead of saying that the field lines of the gravitational force field run in a straight line, it should rather be said: they run like the ray of light or like the trajectory of the force-free body.

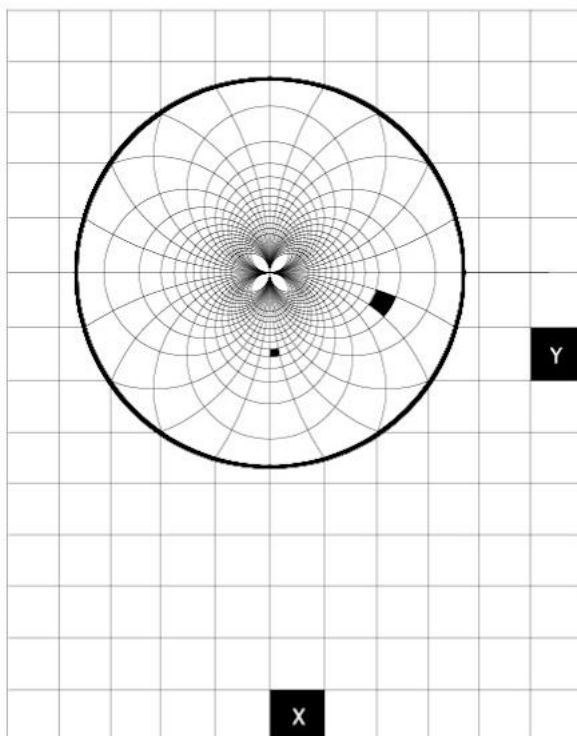

Fig. 23 The spatial metric

Figure 23 shows the connection between the linear metric of the Copernican world concept and the curved metric of the inner world cosmos. Mathematically, this connection is expressed in the transformation through reciprocal radii.

We now have a triple identity: the course of the gravitational field lines, the light beam and the trajectory of the force-free body coincide. There is no doubt that this is correct. The validity of the Kepler-Newton mathematical system of planetary motion (celestial mechanics) clearly proves this, as has already been mentioned several times.

We attach great importance to highlighting these connections for two reasons:

Firstly, we must expect that one day there will be a new definition of the straight line that is not oriented towards the light ray. The need for such an absolute definition is expressed very clearly by E. BARTHEL in "Expansion of space-theoretical thinking possibilities through Riemann's geometry" Astr. Nachr. Vol. 236 p. 142:

"Although no empirical fact can be established anywhere as being absolutely straight, the concept or idea of the straight is something that is clearly established. It is

indeed, the a priori precondition of spatial awareness for the possibility of considering whether something is "straight" or "crooked". We do not derive the contrast "straight - crooked" from any experience, but we have this contrast within us as the foundation of our spatial awareness in such a way that only under this precondition can experience be considered and judged geometrically at all."

If it is possible to create such an absolute straight line excluding the light beam, then it is possible to check the straightness of the light beam by comparing it with this measuring line. If it turns out that the light beam is curved, this result would mean the complete collapse of the astronomical system, which is based on the straight light beam; but only if the triple identity presented above is not taken into account! However, if this identity is taken into account, the correctness of which has been proven, a curved light beam does not mean a refutation of the old system. Because in this case the force-free path and the gravitational field line are automatically recognized as curved, the internal coherence of the Newtonian system is maintained in any case, regardless of how the light beams are curved.

According to Morrow's measurement of the curvature of the earth in 1897, the light beam is indeed strongly curved. The inner world theory is a logical consequence of the regularity of this curvature and its connection with the curvature of the gravitational field and the curvature of the force-free path. The entire Newtonian theory as the basis of celestial mechanics, including modern space travel, retains its full validity even after this theory. The Copernican world view and the inner world theory are therefore simply two different ways of looking at the actual reality that exists.

The second reason why so much emphasis is placed on the emphasized formulation of the threefold identity is the following:

If three things as fundamentally different as gravitational field lines, light rays and the paths of force-free bodies all have one property in common, namely that of the same spatial course, then there must also be a common cause. Otherwise this state of affairs would be at least highly astonishing.

This common cause is the substance of the world, the so-called world ether. The necessity of assuming such an etheric sea that permeates the entire world is explained in more detail in the next chapter. In the Copernican system with its straight-line propagation of light, it is much easier to overlook such a common cause. The straightness of the light beam, the gravitational field lines and the force-free path are simply taken for granted and do not require any further discussion. In a system with curved light propagation, in which force-free bodies move on curved paths and gravitational forces act along curved lines, the common cause of these similar curvatures cannot be overlooked. This cause lies in the etheric sea.

Due to its properties and their spatial variability in the inner world, it propagates light vibrations on curved paths, transmits gravitational effects on such paths and guides moving bodies in the same way.

Space is not empty, as many scientists today claim, but rather space has physical qualities that manifest themselves as guiding or transferring properties in the movement of bodies and in the transfer of light and gravitational effects. In the Copernican view, the spatial qualities in the entire universe are homogeneous (uniform). This means that a cubic meter of space near the sun has exactly the same physical properties (e.g. speed of light) as on Mars or the moon or anywhere else. This results in the straight-line propagation of light with its often mentioned threefold connection. This space has a homogeneous structure, so to speak, or, as we will say from now on: it has a linear metric. This metric is shown or traced in the simplest way by the light rays. In contrast, the inner world theoretical view is based on a spatial metric that is curved in a certain way, as traced by the light rays.

However, this curved metric is causally related to an inhomogeneous (uneven) spatial quality. This means that the physical properties of the (not empty!) space vary from place to place. The speed of light near the sun is different than on Mars or the moon. A closer examination shows that it decreases towards the center of the inner world, quadratically with the height above the earth's shell. Figure 23 shows graphically the connection between the linear metric of the Copernican approach and the curved metric of the inner world theoretical approach. Mathematically, this connection is expressed in the transformation by reciprocal radii. The circle represents the surface of the earth. If the earth is a solid sphere, then space lies outside it. It is divided by a linear coordinate system into spatial areas of equal size, i.e. cubic cells. This space extends in a physically uniform manner to infinite distances. It is unlimited. Every point in this space is uniquely defined by three numbers (of course, only two in this two-dimensional representation). These three numbers are called the coordinates of the point. The movement of a body through this space is described numerically by continuously stringing together such triples of numbers and specifying the time associated with each triple. Such series of numbers are important in space travel, for example. They can be entered into electronic calculators. By comparing the theoretical values with the actual ones, the machine calculates course corrections.

The actual trajectory is brought into line with the theoretical target trajectory by appropriate control impulses. 2003 Helmut I

All of these calculations are based on the Newtonian system. However, if the surface of the earth forms the inside of a hollow shell, then the entire universe is located within this hollow shell. The spatial metric is then not linear. Space is conveniently divided by curvilinear coordinates. The cell size is then no longer the same throughout the universe. It becomes smaller and smaller towards the center. The two hatched cells in Figure 23, for example, correspond to one another via the transformation law. When considering these spatial relationships, one is immediately forced to realize that the physical quality of space increases more and more as one approaches the center. According to the inner world theory, the uniform quality of the spatial elements in the Copernican approach is found to be more compressed, so to speak, the closer they are to the center. Here, too, every point in space can be described by specifying a triplet of numbers.

Everything is exactly as in the Copernican description. Newton's celestial mechanics is also valid here. According to it, the ballistic trajectories of rockets and space capsules can be calculated and described numerically. As an example, a satellite orbit calculated on the basis of Newton's laws is entered in both systems. The points along the orbit indicate the places where the satellite is after every 1000 seconds. The total orbital period is 26012 seconds = 7 hours 13 minutes 32 seconds.

## The Aether Sea and its Properties

When a scientist today speaks of space, he thinks of an endless, empty desert of space, of an absolute vacuum. He likes to imagine away the few dust particles, gas atoms and ions that could alleviate the desolation somewhat, as they impair the flight of his limitless imagination. This eerie ocean of space has a temperature of  $273^{\circ}\text{C}$ , which is absolute zero, the lowest temperature possible. Huge masses of glowing gas race through this vacuum at unimaginable speeds. These are the fixed stars. If you imagine a scaled-down model of this idea of space, in which the fixed stars have the diameter of a pinhead, these pinheads are about 60 km apart.

In between there is empty space! These gas balls are said to have a diameter of several hundred million kilometers and temperatures of many millions of degrees. The pressure inside them is unimaginably high. But these gas balls apparently do not cool down in icy space. Our forefathers admired the splendor of the sky adorned with fixed stars thousands of years ago. Where do they get their inexhaustible energy, which is said to have been radiated into the empty nothingness of space with undiminished strength for many millions of years? A few decades ago, people were convinced that the sun and the fixed stars were made of pure coal.

At that time, this was the best energy source known. With the discovery of nuclear fission by Hahn and Strassmann in 1938, energy-producing processes were discovered that far surpassed coal.

Today, people are convinced that the fixed stars are giant nuclear reactors and the dream of huge, hot, non-cooling gas balls in the icy, empty, infinite nothingness of space seems to have been saved.

This vocabulary of destruction, explosion and dissolution appears to today's purely technical thinking people to be a welcome counterweight to the seemingly threatening idea of a creatively shaping power.

Nature is a magnificent, self-contained system of cycles in which nothing is lost. One thing serves the other. During the assimilation process of plants, for example, oxygen is released. This is not lost, however; it is the life element of animals and humans. The life processes of these creatures in turn produce carbon dioxide, from which the plants in turn produce oxygen and nutrients for other living creatures through assimilation. The closed cycle of water from the evaporation of sea water to the formation of clouds and then to rain is also magnificent.

Overflowing water, the life element of all living things, collects in rivulets, streams and rivers and completes the cycle by flowing back into the sea. This water cycle sets in motion countless other cycles that are intertwined with each other. The driving force for all these cycles is the sun. It constantly gives off its light and heat energy. However, the principle of creation mentioned above requires that it receives back what it gives off in some kind of return process. Eternal one-sided radiation contradicts the most basic and obvious laws of nature. Fixed stars as giant glass spheres that radiate unimaginable energies into an empty universe over billions of years are incompatible with the basic principles actually observed.

There is a polarity between the sphere of fixed stars (sky) of the inner world and the earth shell that envelops it, a unity in the interplay of different functions. Heaven and earth together are an organism whose wonderful size can be imagined in comparison with the human organism. According to the ideas of purely theoretical and mathematically oriented scientists, however, the earth is only a speck of dust that whirls around in the infinite empty space between glowing gas balls of enormous dimensions, exposed to the statistical coincidences of a confused chaos. The earth's only protection against the deadly dangers of space is a wafer-thin layer of air. There is no interaction



There can be no question of this insignificant speck of dust with the infinite empty space; because the polarity between heaven and earth is, in the light of modern science, like the dance of nothingness in the infinite nothingness! The philosophical and ideological consequences of this view lead to an orientation towards nothingness and have a devastating effect on the search for the meaning of life.

The theory of physics, which was valid until the end of the 19th century, that space is not empty but rather filled with a very concrete medium that connects everything and permeates everything, certainly made a lot of sense. Until the turn of the century, no scientist seriously doubted that such a world substance existed.

According to ancient Greek philosophy, this medium was called ether and was used in scientific parlance until the end of the 19th century as "light ether" to explain the phenomenon of light, a medium that as the finest material filled and pulsated through the entire room and in which the light was reflected by wave-like movement of the ether. However, there is no physical similarity with the ether gas used for anesthesia.

According to the theory, it is more a matter of a primary substance from which all matter is formed and into which it can dissolve again. Modern physics is well aware of such processes of annihilation and matter formation. For example, an electron-positron pair can form from light (light is vibration in the ether) under certain circumstances. This process can be observed directly in the cloud chamber.

Conversely, a positron-electron pair can disperse into light, i.e. into ether vibration. When the vibration has come to rest, there is no longer any sign of the pair of particles that were there before. It has dissolved into the primordial substance, into ether, similar to a piece of ice in water.

According to this idea, the ether is the seat of all electrical and magnetic phenomena. Magnetic fields are created around wires through which current flows, and these fields are so strong that they can, for example, set heavy trains in motion. This would never be possible if space were empty.

An electric motor basically consists of two parts (Figure 24); the stator, which is the part that is firmly bolted to the locomotive, and the rotor, which is the rotating part that rotates on the stator and is connected to the drive wheels. As soon as the rotor starts to rotate, the wheels turn with it and the heavy train starts moving. Several thousand horses would be needed to develop such tremendous power.

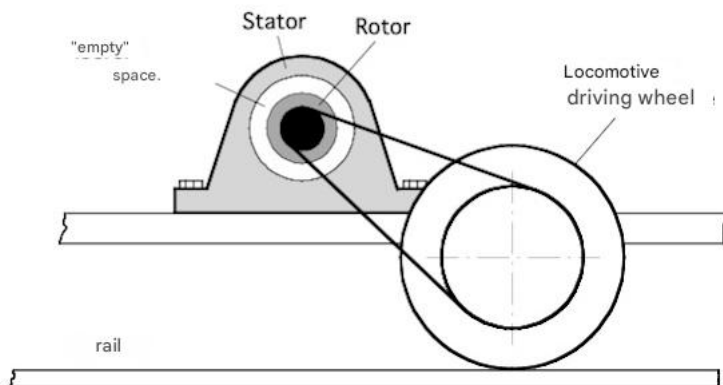

Fig. 24 The electric motor transforms etheric force into mechanical force

This force is now developed in the "empty" space between the stator and the rotor, although there is no mechanical connection between these two parts. What enormous forces cause the rotor to rotate? Empty space, perhaps? Such a nonsensical idea can only arise from ideas that are far removed from reality. Every normal thinking person immediately recognizes that something is happening in the space between the stator and the rotor. Something is changing here. A force is exerted here. A force cannot act from empty space, from nothing. A magnetic force field is created in this space. But this is probably nothing other than ether moving in a certain way, which is converted into mechanical energy in the electric motor.

is converted.

Electric fields can also form in the ether. Two electrically charged metal balls, for example, attract or repel each other, depending on the polarity of the charge. This force cannot possibly be transmitted through empty space. Instead, an electric field is formed between the balls, perhaps a tension in the ether.

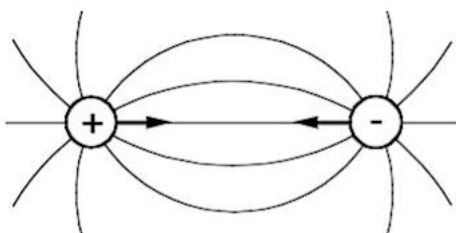

Fig. 25 The electric field between charged metal balls

In contrast to the ether currents in the magnetic case, in the case of the electric field one could think of a static change in the ether, a state of tension. This remains unchanged as long as the charges cannot balance each other out. However, as soon as the charged metal balls are allowed to do so, for example by a metal wire between the balls, the tension in the ether is reduced. This causes the ether to move, i.e. a magnetic field is created.

This interplay between electric and magnetic fields was first recognized by the English physicist Faraday in 1831. Every changing electric field generates a magnetic field and vice versa. In the image of the

This is called ether conception; when an ether tension balances itself out, an ether flow is created.

The mathematical description of these physical processes and relationships is completely successful and complete in Maxwell's equations. (Maxwell 1831-1879, English physicist) It is also interesting in this context that these Maxwell's equations of electrodynamics bear a striking resemblance to those of hydrodynamics (fluid mechanics).

This striking similarity tempted many physicists to explain the phenomena of electricity as a hydrodynamic process in the ether. However, all attempts in this direction to date have failed. This is because people have always overlooked the fact that the inertia of matter also plays a role in hydrodynamic phenomena. But this also has its origin in the ether. The properties of the ether can therefore only be compared to those of liquids to a limited extent.

The properties of ether are of an elementary nature. They cannot be recognized directly with our human senses, but only indirectly via the variety of recognizable phenomena in which ether effects play a role. One of the most exciting discoveries in physics was made by Heinrich Hertz (physicist, 1857-1894) when he discovered the propagation of electromagnetic waves in space. An electromagnetic wave is a periodically oscillating transition from an electric field to a magnetic one and vice versa. In the image of ether, a constant back and forth oscillation of ether substance, i.e. a constant change between tension and flow in the ether. This state of oscillation propagates in space, i.e. in the sea of ether as a wave, similar to the water waves around a stone thrown into water.

This phenomenon has been used technically for a long time. Radio waves, from the long waves that span kilometers to the VHF and decimeter waves of television, as well as radar waves, are all such electromagnetic oscillations in the ether. Maxwell recognized that light in the visible and invisible spectral range is nothing other than electromagnetic oscillations with a very short wavelength. The speed of propagation of such oscillations is 300,000 km/sec. Now the question again is whether empty space can oscillate. Of course, such an idea is completely absurd.

The "vibrating nothingness" is on the same line of thought as the idea of the swirling nothingness in the infinite nothingness.

After these few examples, the layman will have already recognized the existence of a world ether as a matter of course, because he is not hindered from seeing clearly by a thicket of prejudices and opaque connections. The expert is at a disadvantage compared to the layman's quick, intuitive understanding. Although he knows exactly the infinite variety of phenomena and can organize them into a scheme, he often loses sight of the most obvious, tangible thing. He is standing in the middle of the forest, so to speak, and does not recognize it.

The debate about the world ether had occupied scholars for around 20 years before and after the turn of the last century. For physicists in the 18th and 19th centuries, it was a matter of course, although it had never been directly proven. To remedy this deficiency, two American physicists, A. Michelson and E. W. Morley, conducted an experiment in Cleveland, USA in 1881 to determine once and for all whether there really was such a thing as a world ether.

L. Barnett gives a vivid description of the experiment in the book "Einstein and the Universe" (Fischer Library): "The principle underlying this experiment was quite simple. They assumed that all of space was a motionless sea of ether, but that the movement of the earth through the ether could be detected and measured, much like sailors measure the speed of a moving ship. It is, as Newton had shown, impossible to detect the movement of a ship in calm seas by any mechanical experiment on the ship itself. The sailors determine the speed of a ship by throwing a "log" overboard and observing the knots unwinding on the log line.

Likewise, in order to determine the movement of the earth through the etheric sea, Michelson and Morley threw a "log" overboard in the form of a beam of light."

The details can be found in any physics textbook. The apparatus that Michelson and Morley constructed was so sensitive that it could have measured the orbital speed of the Earth, which according to the Copernican theory is 30 km/sec!

The whole experiment was planned and carried out with great care and precision. The result was clear: there was no movement of the Earth planet in relation to the etheric ocean, not even a hint of it. Barnett describes the consequences very correctly in his book mentioned above:

"The Michelson-Morley experiment presents physicists with a confusing alternative: either they had to throw out the ether theory, which had served so well in explaining electricity, magnetism and light, or, if they held on to the ether, they had to give up the even more venerable Copernican theory according to which the earth moves.

Many physicists find it almost easier to believe that the earth stands still than that waves, namely light waves and electromagnetic waves, can exist without a material substrate. The dilemma was difficult and for a quarter of a century it divided opinions. Many new hypotheses were put forward and then rejected." The experiment was repeated with the utmost precision and effort in the years 1902-1906 by Morley and Miller in Cleveland and in 1930 by G. Joos in the Zeiss works in Jena.

The result was always the same: the apparent speed of the Earth in relation to the ether was always zero. From the perspective of the inner world theory, this experiment is a refutation of the Copernican world view and proof that the Earth is standing still. From the perspective of modern science, however, the negative outcome of the experiment does not mean a death blow for the Copernican world view.

With the help of the special theory of relativity, the correctness of which cannot be doubted, the outcome of the experiment can be explained very clearly, so that one can conclude that the Copernican theory has not been refuted. This classic Michelson-Morley experiment provided the impetus that led A. Einstein to develop the theory of relativity.

As valuable and indispensable as Einstein's special theory of relativity is for all areas of physics today, it has nevertheless only increased the general mental confusion regarding the ether problem. After the turn of the century, the opinion spread like an epidemic that Einstein's theory of relativity had finally refuted the old idea of the world ether. A period began in physics in which abstraction and wallowing in empty concepts were elevated to the physicist's highest virtue. This tendency has continued to grow to this day, especially after the advent of so-called "wave mechanics".

For example, Louis de Brooglie (Nobel Prize winner for physics) writes in the book: *Physics and Microphysics* (Claasen-Verlag Hamburg/Baden-Baden 1950): "One thing is still certain today: while mechanical vibrations and sound require a material carrier, a vibrating medium that transmits them, light, which is independent of matter, can propagate without any carrier, despite the wave aspect that it often presents to us. Through light we have learned to understand the immensity of the universe. It has revealed the existence of nebula stars at such an enormous distance that, despite its speed, it takes hundreds of millions of years to travel them. Without perceptible mass and electrical charge, it endlessly traverses space without needing a carrier.

"Despite this enthusiasm outside of the field, there are still physicists today who have kept a clear view and who have recognized that modern physics cannot provide any argument against the existence of a world ether. For example, K. Jellinek writes in his book, *World System, World Ether and the Theory of Relativity: An Introduction for Experimental Scientists* (Basel 1949):

"In our age, Einstein's genius has profoundly influenced the development of physics through his abstract theory of relativity. The same is true of researchers such as de Brooglie, Heisenberg, Schroedinger, Dirac and Born, who created abstract quantum (or wave) mechanics.

However, both the theory of relativity and wave mechanics must gradually be translated into a descriptive language. This is a very urgent task for physics, since most scientists cannot stop at differential equations, but must have descriptive images." Just as one cannot understand the agile movements of a flying bird if one knew nothing about the sea of air and the interaction of the forces between the air and the animal's wings, the world of matter cannot be understood without the sea of ether that surrounds and permeates everything. All physical processes, from the effects of gravity and inertia to electric and magnetic field effects and the processes of matter formation and annihilation, can only be recognized in a one-sided and distorted way and can only be understood in an imperfect way without the other side of the world, which is invisible but no less real than the invisible.

No matter how great and fascinating the discoveries of the natural sciences, they are ultimately not enough to paint a complete picture of nature that could even hint at its deep beauty and inner coherence. What a living organism really is, with countless but finely coordinated individual functions and cycles, is not recognized.

Instead, what we see today from the dusty books of purely materialistic science is a distorted skeleton without flesh and blood, not to mention spirit and soul. Is this portrayal exaggerated to the point of being negative? Then compare the miracle of the human organism, which today's science does not even begin to understand, with the world organism.

This must be even more wonderful, because there is an ascending line from the smallest inanimate building block of matter through the multitude of living organisms of ever higher levels of organization up to man. The ascending line cannot suddenly break off here, because why should the highest spiritual wisdom in the events of nature suddenly turn into chaos, in the form of explosion, scorching heat, emptiness and dissolution?

This break in the understanding of the natural process is not a peculiarity of nature itself, but is due to the disruption of human cognitive ability and error, or to a wrong philosophical approach, an ideology or a refusal to know. The idea and effect of an etheric sea is almost tangible, especially in the effects that we know as the inertia and weight of matter. The next section will clarify this.

## Inertia of Matter and Gravity as Effect of the Aetheric Ocean

All material bodies without exception have two properties:

1. They are heavy, i.e. they are subject to a force that is directed perpendicular to the earth's surface.
2. They are inert, which means that they resist any kind of change in motion in the way described by the law of inertia (see previous chapter).

In the following, we will first take a closer look at the second property.

Let us imagine ourselves at the wheel of a well-sprung car driving at a constant speed on a flat, straight road. We are sitting in our seat as calmly and comfortably as we would on the sofa at home. We do not feel any force, apart from gravity, which we will not consider here. Our body therefore moves along the road completely force-free. According to the law of inertia, we are moving "straight and uniformly", as we assumed at the beginning. Now we are driving into a right-hand bend. At this moment we are caught by a force that pushes us to the left and we have to hold on tight to avoid being pulled out of our place. In a left-hand bend the direction of the force is reversed and we are pushed to the right. Suddenly we have to brake, i.e. reduce our speed. This mysterious force immediately catches us from behind and pushes us in the direction of travel. When we accelerate, i.e. increase our speed, it finally pushes us backwards against the seat back.

Every driver should be afraid of this strange force, the existence of which we generally take for granted, and the faster his vehicle is, the more he fears it. Experience shows that it can have devastating effects if the change in speed is very large, for example in an accident. This so-called inertia force can easily crumple heavy car bodies like paper, like a giant fist. All of this is obvious and natural or even logical, some people will think. Everything is clear to me, what's the problem here?" Those who think like this are right from the point of view of practical life, where it is enough to know the phenomena and to be able to deal with them.

The deeper, scientific approach does not stop here, but tries to penetrate into the context and asks above all about the mostly invisible causes of the phenomena. In our example with the driver in the car, the following must give food for thought:

At the moment of braking or cornering, in short, at the moment of changing speed, a force suddenly becomes effective and perceptible that was not there when driving straight ahead at a steady pace. If an effect suddenly appears in the world of phenomena accessible to our senses that was not there before, we look for a cause. This is the "natural", the "logical".

But where can the cause be found? Did the inside of the car change in any way when I braked? Did it get warmer, or did the objects around me change their color, shape, or hardness? Or can any chemical reactions be detected? No! Everything has remained exactly as it was when I was driving straight ahead at a steady pace. There are no external changes inside the car that can be detected by the senses. If we could not immediately recognize the change in speed by comparing it with the landscape outside, for example in the interior of a ship, the astonishing situation arises that without the slightest cause my body is suddenly seized by a force and pushed in some direction!

If, for example, a tree that was originally standing still suddenly bends to the side and its branches and leaves start to move, we look for the cause of this visible phenomenon and immediately recognize that a wind has arisen. We do not see it, nor do we need to feel it; we deduce this with the help of our experience and our intellect. But one should argue just as logically and compellingly if the force of inertia suddenly takes effect on a body.

Then something must have changed in the body's environment. The cause of the suddenly very real and perceptible force of inertia cannot grow out of empty space, absolute nothingness. Rather, it lies in the surrounding ether. We cannot see this directly, just as the air around us is invisible. But just as we recognize the air and its properties indirectly through many experiences and experiments, we also recognize the invisible ether through the many effects such as electricity, magnetism, light, heat, etc.

In the force of inertia, we encounter another visible and tangible, even measurable effect of the ether. We move in this sea of ether with all its strange properties. We cannot see it, but we are so familiar with it and its properties and have grown so closely with it through constant practice and adaptation from childhood that we are easily inclined to overlook it or even deny its existence. But that would be just as foolish as if fish wanted to ignore their life element, water, just because they are so completely grown together with it and cannot see it. Or if a bird were to say: "Air? What is that supposed to be?"

For me, only what I see is real, and I cannot see something like air, even if I try my best. Why don't I fall down? Because I move my wings in the right way. The result is that I fly, isn't that logical? So what is the point of the idea of something like air? Why make a problem out of the most natural process in the world?"

However, many modern scientists still argue in the same way that this bird could think when they talk about space and inertia, i.e. when they deal with the phenomenon of inertial forces, which always become effective and noticeable the moment the state of motion of any material body is changed, be it through acceleration or deceleration or through deflection from the direction of motion. The question of the cause of these force effects cannot be answered by modern physics.

Air is not a possible explanation, because the effects of inertia are just as present in a vacuum (e.g. on the moon). This creates the grotesque situation for modern science that forces exist that arise from an absolutely empty space, from nothing. Most modern physicists are not bothered by this. They are content with the mathematical description of these processes.

Their great mastery in this is undisputed. In addition, abstraction is particularly admired today as an expression of the "higher development of the human spirit". Some scientists are proud of being able to move systematically in a thicket of inconsistencies. To support and justify some abstract worldviews, they always have a few scraps of epistemological philosophy at hand, with which they defend themselves against attacks from the camp of those who are more concerned with the visual aspect of nature. The famous English astrophysicist A.S. Eddington writes on this topic in his book:

"The Nature of the Physical World" (Cambridge 1929, p.137): "We must get rid of the idea that the word space in natural science has something to do with emptiness. Thus the rather summary statement that Einstein's theory reduces the force of gravity to a property of space should not raise any concerns. The physicist in no way conceives of space as empty.

Where it is empty of everything else, there is still the ether. Those who for some reason do not like the word ether scatter mathematical symbols freely in the vacuum, and I certainly assume that they think of some kind of characteristic background for these symbols. I do not think that anyone proposes to base even so relative and fleeting a thing as a force on a total nothingness." (Compare the quote from Louis de Brooglie.)

We are therefore in very good company if we assume that a space from which such powerful effects as the forces of inertia and gravity emerge cannot be empty, but must be filled with a very concrete medium, the world ether. This primordial substance cannot be directly perceived by our sense organs, but only indirectly via the electrical, magnetic, gravitational and inertial effects that are accessible to our senses.

Nor should one ascribe to this ether the idea of materiality in which we see material bodies. These have arisen from the ether substance, are, so to speak, special manifestations of the ether and can dissolve into it again. The ether itself is just as real as matter, which floats, so to speak, in an etheric sea, similar to pieces of ice in water, to use this vivid image again.

In the effects of inertia we now encounter an interaction process between matter and ether. Our senses, however, only perceive a part of this process: the movement of the bodies and the effects of force. The other part, the processes in the ether, remain invisible and can only be grasped mentally. If we deny the reality of this invisible partial process, we end up with abstraction, with a purely formal, descriptive view of nature, which is not possible to understand the overall context.

What happens in the ether when a body is set in motion at an accelerated rate?

Of course, it is not possible to make a clear statement about this. What is certain, however, is that the space around the accelerating body, i.e. the ether, changes in some way. A field is created, either a flow field, a tension field or an oscillation field. The latter is the most likely. The creation of this field requires energy. This is supplied via the force necessary to accelerate the body. The body is then said to have kinetic energy.

In reality, however, this energy is not in the body itself, but in the etheric field that surrounds it. The body only serves as a mediator, so to speak, which transforms the external force into the creation of an etheric field. If the external force stops, the growth of the etheric field also stops, but it remains and moves with the body.

This state remains until something tries to slow the body down. At that moment the ether field breaks down. The energy released in the process now acts on the body and tries to push it further. Suddenly a force attacks the body and pushes it in the direction of travel, and that is the force of inertia that we feel when driving a car, for example.

It does not come from empty space, from nothingness, but has its cause in the ether. 2003 Helmut I Diehl 69

If braking or accelerating causes act on a moving body, the energy of the ether field does not change. This means that the body moves uniformly at a constant speed, or it remains at rest (in which case the ether field is zero).

But this is exactly what the law of inertia expresses.

What caused so much headaches for ancient astronomers, right up to Kepler and Galileo, was the question of the force that keeps a planet in motion. Without a constant drive, they argued, they would soon come to a standstill, "run out of power". Today we laugh at such ideas, but that is actually unjustified. The ancients' question has remained unanswered by science to this day.

The term "inertia" was simply coined to express the fact that the planets orbit forever. The ancients knew that too. Their question was more like: "Why do they orbit forever?" They looked for the cause behind the visible phenomenon. But this is still unknown to science today because it does not know what to do with a world ether, which in turn can be explained by the prevailing concept of the universe.

From our point of view, the question of how the planets are propelled made a lot of sense. The planets actually have their "engine" in the etheric field surrounding them, which would drive them forward against any possible resistance. The energy required for this was taken from the etheric field.

In space, however, there are no decelerating effects and the energy of the ether field is thus conserved. If the inertia effect of matter did not exist, our world would look very different. For example, the hammer would then be a useless tool. Its function is based on the fact that it is "set in motion", i.e. a powerful ether field is built up around it, which contains a lot of energy.

If the iron mass of the hammer hits an obstacle that slows it down, such as a nail, the ether field is quickly reduced, the inertial force takes effect and drives the hammer mass further, and the nail is pressed into the wall. But if the whizzing hammer were not surrounded by an ether field, no inertial force could take effect. The iron mass would simply stand still the moment it touched the nail. Because where one body is, another cannot be at the same time.

The physical term "momentum" would then not exist at all, because it is always connected to the kinetic energy of the body in question, and this is contained in the etheric field. If it were possible to find a way to switch this off or neutralize it by researching the etheric field of moving bodies, then car accidents, for example, would be a thing of the past!

Because only the unleashed forces of inertia are the cause of these and many other destructive effects. Cars and airplanes could then change direction abruptly without causing damage, and braking and starting would only be ridiculed props from "Grandpa's times".

However, the list of such visions of the future is intended only to illustrate and deepen the above statements. This would certainly not serve the well-being of humanity in any way, but would rather harm it. The effects of inertia are very closely related to the effects of gravity.

The unravelling of gravity would result in man conquering and occupying the spaces above. In the language of antiquity, this would be equivalent to the expression storming the heavens. The ancient, foreboding fairy tales tell of the devastating consequences of such undertakings for mankind, because the destructive rage of man demonstrated on earth does not stop at the cosmos either.

## Heaviness and gravity

In the following, we will discuss the property of bodies mentioned at the beginning, "gravity". However, this is a special case of a general cosmic phenomenon, so-called gravitation.

Isaac Newton discovered that all masses attract each other. The magnitude of this gravitational force depends on the size of the two masses and the distance between them. The larger the masses and the smaller the distance, the greater the force of attraction. For example, two 1 kg pieces 1 m apart attract each other with a tiny but measurable force.

The sun attracts the planets and influences their orbits, the planets attract each other, the moon pulls the spaceships towards itself and allows the astronauts to walk upright, similar to on Earth.

The mountains of water caused by tidal movement are also piled up by the gravitational forces of the sun and moon. On the other hand, the orbits of the sun and moon are determined by the gravitational force between the Earth's shell and these celestial bodies.

The gravitational effect is therefore a very general interaction between all masses that is valid throughout the entire cosmos.

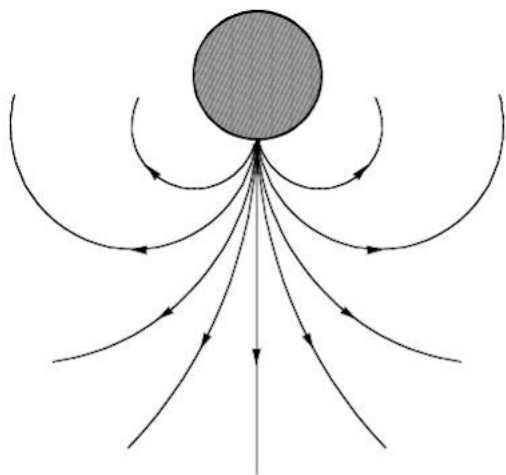

The crucial question is whether the cause of gravity is to be found in the masses themselves or in the surrounding ether. Here too, as expected, the opinions of experts are divided. According to the inner world theory, it is clear from the outset that the effects of gravity and gravitation are based on an interaction between ether and matter.

Since the direction of gravity points radially away from the center of the world towards the Earth's shell, one automatically thinks of a repulsive force emanating from there. The fact that this can only be partially true can be seen from the fact that this force would have to increase as one approaches the center.

The exact opposite is the case. Gravity becomes weaker the further you move away from the Earth. We have known this for a long time and can now easily measure it.

Fig. 26

Gravity is lower on mountains than at sea level. In addition, walking on the surface of the moon and the surface of the earth would be made possible by two different forces, a gravitational pull from the moon and a pressure pull from the earth.

This seems unsatisfactory and improbable. The problem is solved in a much more uniform and convincing way if one assumes that an ether vibration is emitted from the center in all directions. The radiation sources of this "gravitational vibration" are perhaps the fixed stars and other visible or invisible objects in the sphere of fixed stars.

Perhaps the radiation source is located inside the sphere of fixed stars and penetrates through its solid shell to the outside. In any case, the energy of the source must be extraordinarily large, because it sets the entire cosmic etheric sea into vibration. However, this is not limited to the space inside the earth's shell, but extends far beyond it.

The gravitational vibration also spreads far beyond the Earth's shell. The vibration is therefore very penetrating. Its spread is not greatly hindered by matter, but to a certain extent. This penetrating ability indicates a low vibration frequency. The oscillation period would therefore be very long.

Every source of gravitational radiation on the sphere of fixed stars emits a beam of radiation like that, as shown in Figure 26. How does this oscillation spread? Certainly not in a straight line, because straight lines are alien to this world view. The simplest and most plausible decrease would be a course corresponding to the light oscillation, as outlined by the curved space metric.

The ray of light oscillation, the ray of gravitational oscillation and the trajectory of the force-free body would thus be identical.

From each radiation source on the fixed star sphere a beam of rays emanates, which spreads out in a cluster-like manner as in

Figure 26 shows the entire gravitational radiation field as the superposition of many such individual beams. There are as many individual beams as there are radiation sources on the sphere of fixed stars. This is certainly an enormous number, comparable to the number of fixed stars. Perhaps the fixed stars themselves are these radiation sources. So much for our basic assumptions. What conclusions can be drawn from this? Every source of gravitational radiation on the sphere of fixed stars emits such a beam of rays. Firstly, this superposition of many beams of rays means that every place in space outside the sphere of fixed stars is flooded with a dense network of rays that come equally from all directions.

This is shown in Figure 27. At P there should be some piece of matter.

It is hit by gravitational rays from all sides. Of the enormous, almost infinite number of rays that actually emanate from the sphere of fixed stars, only a very few are drawn, namely those that hit the piece of matter. Those that pass by are of no importance for our consideration (of course, each radiation source does not emit just a single ray, but a whole bundle of rays, as is indicated in Fig. 29 for one of the 8 sources drawn).

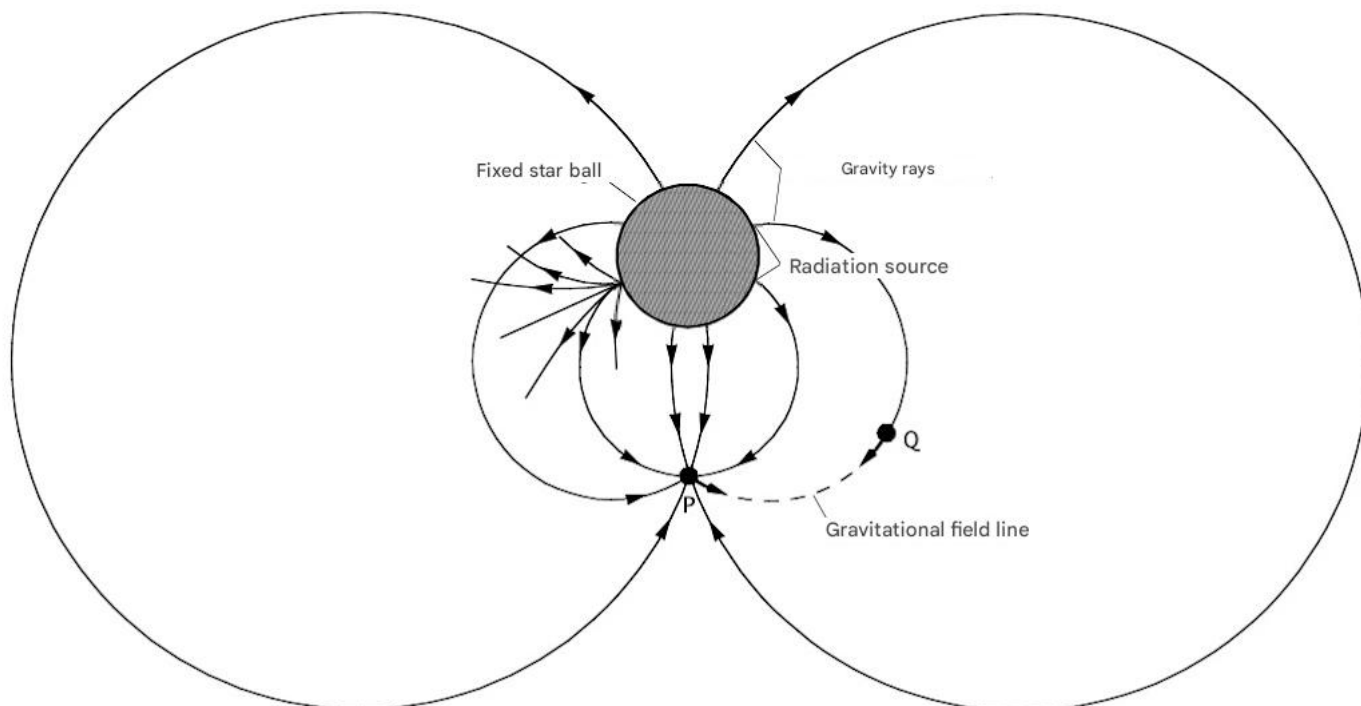

Fig. 27 General gravitation as the effect of a gravitational oscillation emitted by the sphere of fixed stars, which is weakly absorbed by material bodies.

We assume that the radiation is weakened a little as it passes through the piece of matter. There is therefore some kind of interaction between the radiation and the matter, which removes some of the radiation's energy. Radiation is absorbed. This means that every ray that hits the body exerts a certain force on it.

The beam coming from the left, for example, pushes the body to the right, while the beam coming from below pushes it upwards. However, since beams arrive equally from all directions, the resulting force on the body is zero. For any beam, there is a beam coming from the opposite direction. The two associated forces are therefore exactly opposite and cancel each other out. This means that although the entire universe is permeated by gravitational oscillations from all directions, no force acts on a material body somewhere in (otherwise matter-free) space. The body remains at rest (or moves on a trajectory according to the law of inertia), it floats in space without any force.

This situation changes, however, as soon as a second piece of matter is located near this body, e.g. at Q in Figure 27. This too is hit and penetrated by gravitational radiation from all sides. The radiation is also slightly weakened as it passes through this piece of matter.

There is now a beam that first passes through the body at Q and then, weakened, hits the body at P. For this body, there is no longer any radiation or force equilibrium. The body at Q casts a kind of "gravitational shadow". The body at P is now pushed in the direction of this "shadow C" by the other beams. It therefore experiences a force effect in the direction of the body at Q. Conversely, there would also be radiation or force equilibrium for the body at Q alone (if the body at P were not there). But if the body at P is there, then this body also casts a kind of "gravitational shadow".



a "shadow" in the direction of which the body is pushed at Q, because in this case there is no radiation equilibrium for it either.

In short: Both bodies tend towards each other under a certain force (indicated in Figure 27 by the thick arrows on the bodies).

This force is called gravitational force. It actually exists and can be measured with sensitive torsion balances. Gravity is generally thought of as an attraction between bodies. However, as long as there is no causal explanation for the phenomenon, it is equally possible to speak of pressure.

According to this attempt at explanation, the gravitational force would be a pressure force that has its origin in the interaction of matter with the gravitational oscillation that fills the entire universe and is emitted by the sphere of fixed stars. The intensity of this interaction depends on the type of material of the bodies in question. It is small for wood and aluminum, for example, large for iron, brass, copper, and very large for lead, gold, and iridium. It is said that bodies made of such materials have different "densities".

Of course, the amount of material a body is made of also plays a role, i.e. ultimately the number of atoms it is made of. The interaction of gravitational radiation with a body, or in other words its ability to absorb gravitational radiation, is therefore determined by the number and type of atoms that make it up.

These two factors determine the so-called "mass" of the body in question. The following applies to the gravitational effect between two bodies: it is greater the greater the masses of the two bodies and the smaller the distance between them. This is because the "shadow" cast by the two bodies on each other is more intense the greater the radiation absorption determined by the mass and the closer they are to each other.

The exact relationship between the gravitational force, the heavy masses of both bodies and their distance from each other is described in mathematical form by the famous Newton's law of gravitation, which also retains its full validity in the inner world theory.

Now it must be pointed out that the force of gravity does not act in a straight line, but along a curved line, as shown in Figure 27. If the two bodies at P and Q were able to move freely in space, they would move towards each other on the dashed path. This curve is called a gravitational field line. It is therefore curved according to the space metric of the inner world theory, just like the light beam or the path of the force-free body.

### **This previously described triple identity is the important basis of the inner world theory**

One of the two bodies can be imagined as the moon, for example. It has a huge mass and therefore absorbs a lot of gravitational radiation. Another body, such as a spaceship, is therefore pushed towards the moon by a very strong gravitational force. The spaceship falls towards the moon at great speed, while the moon remains at rest due to its large mass (theoretically, the moon also moves a little towards the spaceship).

If the spaceship is steered in time so that its course passes the moon, it will swing into a circular or elliptical orbit around the moon. A centrifugal force is created that balances the gravitational force: the spaceship will not crash, it will become a satellite of the moon. Many planets are orbited by natural satellites, their moons. Mars, for example, has 2, Jupiter has at least 12, Saturn has 9 and also a ring of probably dusty matter.

The sun is also such a central body that is orbited. The mechanism that keeps the planets on their orbits is exactly the same. The very large mass of the sun alone would cause all the planets to fall towards the sun under the influence of gravitational force. Only the proper motion of the planets in the etheric sea prevents this, since the inertial forces caused by this counteract the gravitational force.

(Centrifugal force is nothing other than a special manifestation of the force of inertia).

The orbits of moons and satellites around planets are therefore an expression of the interplay of two forces: the force of inertia and the force of gravity. The cohesion and dynamics of the entire material universe are based on the interplay of these two "forces of the cosmos".

The assumption of a gravitational oscillation in the etheric ocean now gives us the possibility to calculate gravity and

to explain the cohesion of the earth's shell.

Let us assume that the universe was in the state before its creation and that the entire infinite space consisted of the etheric sea in which matter floated evenly distributed in a chaotic state. There was still no gravitational oscillation and no earth shell. Somewhere in the middle of this chaotic, matter-filled space desert, a center was created from which the etheric sea was set in vibration. We ask ourselves the question: what would happen as soon as this gravitational oscillation was "switched on"? Answer: the chunks of matter (including liquids and gases) would start moving from that moment on. They would move toward each other, driven by the gravitational force between all particles that suddenly became effective.

More and more matter would clump together.

The masses would become ever larger and the gravitational forces ever stronger.

However, since the matter was evenly distributed around the center of vibration before the onset of vibration, the agglomeration now also occurs evenly, i.e. spherically symmetrically around the center. The matter that was previously distributed chaotically would grow together to form a spherical shell around the center. The earth's shell would have been created! It would enclose the center like a stable, brick vault, as if it were a protective, indestructible shell. The astonishing agreement between the idea of the development of the material cosmos described here and the ancient myths and, for example, the creation story presented in the Bible is hard to miss.

The "solid" corresponds to the vibration center. The "separation" of the waters around the solid corresponds to the formation of the earth's shell from the chaotic primordial elements. Does this depiction, transmitted from ancient Egyptian culture, really only embody the primitive idea of a "humanity dozing along in a half-sleep," or do its roots of knowledge perhaps reach much deeper than our modern science can imagine?

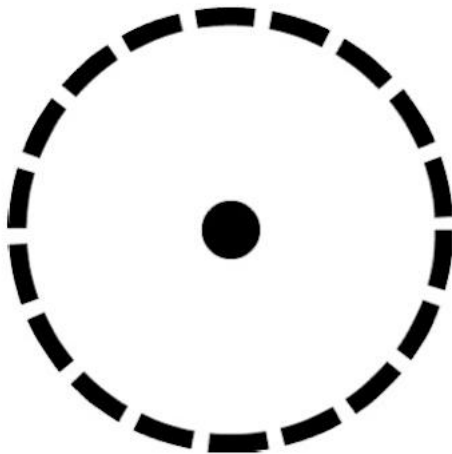

Fig. 28

This shell of the earth is a very stable structure. You can get an idea of this if you mentally break it down into many separate parts. (Figure 28) What would happen?

Would the cohesion be destroyed and would the whole thing collapse? Absolutely not, because as long as the etheric sea vibrates, the parts would fall towards each other under the influence of gravitational forces and all gaps would immediately close again. The existence of the earth's shell is thus already secured by the basic physical principles of the material cosmos; according to these principles it can neither burst apart nor collapse. It is, as already described in the books of wisdom in ancient times and written in the Bible, "firmly founded".

But if the gravitational oscillation were to stop, the immediate consequence would be that the gravitational force that holds the individual building blocks together would disappear and everything would dissolve into chaos again. Based on this description, it is logical to

recognize gravity as a special case of the general gravitation between all masses.

For example, an apple hanging from a tree has a certain mass and is pressed against the very large mass of the earth's shell beneath it, i.e. it falls towards the earth's shell at the first opportunity. It looks as if it is being attracted to it. This is why we also speak of gravity. In our opinion, the term earth's pressure force would be better. Figure 30 shows again in detail how it arises from the gravitational oscillation. A body is supposed to be located just above the earth's shell, at P. Eight gravitational rays are drawn that hit the body. Some reach it directly and unhindered, namely rays 1, 2, 7 and 8. Rays 3, 4, 5 and 6, on the other hand, penetrate the earth's shell twice on their way and are weakened as a result. Coming from below, they cannot therefore compensate for the force of the four unweakened rays coming from above. There remains a resulting force that pushes the body downwards perpendicular to the Earth's shell, namely gravity. (indicated by the vertical arrow S in Figure 30)

A warning should be given here to avoid a misunderstanding. Gravity is to be regarded as a pressure force and is always perpendicular to the earth's surface, i.e. directed radially away from the centre. The gravitational field of the earth's shell has a radial structure. However, this should not lead to the false conclusion that the radiation causing it also runs radially and in a straight line from the centre outwards, because otherwise the earth's shell would be immediately blown apart by gravity and the fragments would fly outwards like the splinters of a burst grenade. The cohesion and stability of the earth's shell is rather a result of the curved spread of the gravitational radiation, as it is caused by the curved spatial metric.

The fact that gravity as a resulting pressure force exists at all is due to the partial shielding of the 2003 Helmut I Diehl 74

Gravitational radiation through the Earth's shell, the radial structure of the Earth's gravitational field is based on the spherically symmetrical structure of the universe including the Earth's shell.

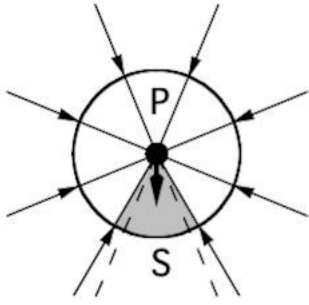

Fig. 29 Gravity as a special case of general gravitation.

Now the question remains whether, according to the idea developed here, gravity decreases with increasing height above the Earth's shell. It is known that this is actually the case, as has already been mentioned. The answer is made clear in Fig. 30 in comparison with Fig. 29. Every body in space is hit by unattenuated gravitational radiation from a certain solid angle range, and by radiation weakened by the Earth's shell from the remaining range. This area is shown in shaded colors in both figures. The ratio of these two solid angle ranges is now decisive for the size of the resulting gravity.

Compare the detailed sketches in Figures 29 and 30, which show the immediate surroundings of the body.

The smaller the area of weakened radiation, the more completely all forces from different directions compensate each other, and the smaller the force of gravity is. However, the two figures clearly show that this tinted area becomes smaller with increasing altitude.

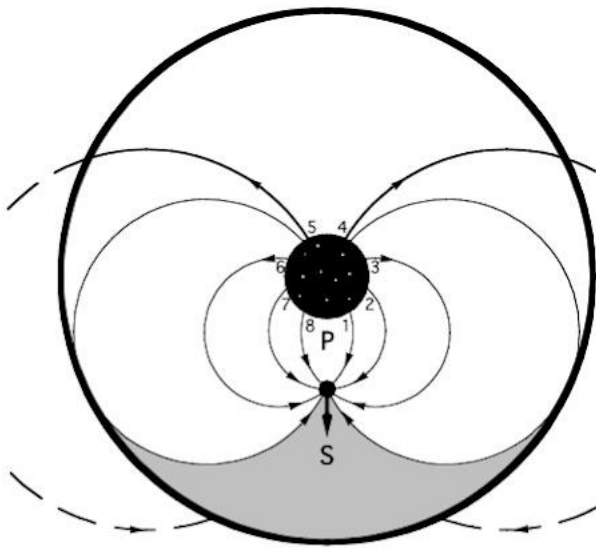

Fig. 30 On the height dependence of gravity

have passed through the Earth's shell exactly once, and are therefore all weakened to approximately the same extent. The individual forces therefore largely cancel each other out.

This means that gravity decreases with increasing altitude. At very high altitudes, close to the sphere of fixed stars, the tinted area becomes tiny. The gravitational radiation then hits practically equally from all sides, the individual forces cancel each other out completely, and the resulting gravity at this altitude is then vanishingly small or practically zero. Directly at the earth's surface, the tinted area is exactly as large as the non-tinted area. But this is the largest possible value. Gravity has its maximum value here.

Another interesting conclusion, which can be drawn from the relevant considerations, is that gravity must decrease again when the earth penetrates the earth's shell. Gravity measurements in deep mine shafts show that this is actually the case. Theory and reality are therefore in complete agreement.

What's more, outside the Earth's shell there can no longer be any gravity, because there all gravitational rays that hit a body

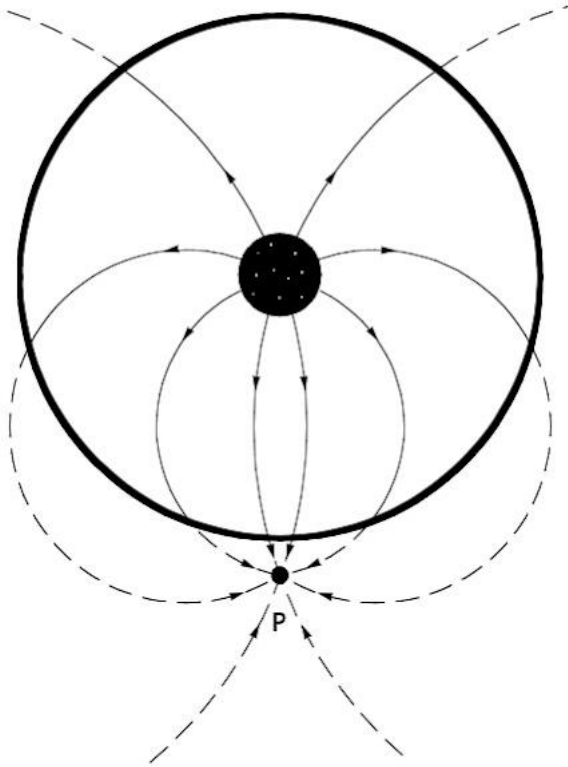

Fig. 31

This is shown in Figure 31, so gravity is shielded from the outside by the Earth's shell, although gravitational radiation penetrates through it. It is conceivable that the moon, the sun and the planets, which are also hollow bodies, have their own gravitational field inside, but this is not visible from the outside because it is shielded by the shell of the celestial body. Conditions inside the celestial bodies would then be similar to those on the inner surface of the Earth's shell.

For example, upright walking would also be possible there (of course, this is only speculation).

All of these statements made so far are merely logical consequences of the hypothesis of a gravitational oscillation with certain physical properties that was put forward at the beginning. Some people will raise reservations here: "How can one base an understanding of the structure of the universe with all its complicated force and movement mechanisms on a hypothesis? Doesn't everything depend on whether it is correct or incorrect?"

This objection is correct. But it is important to remember that all science as we understand it today follows this path. It began with Copernicus. His working hypothesis was that the sun was at the center of the planetary system.

However, he was not able to prove the correctness of his hypothesis. Only the logical conclusions and practical successes retrospectively justified his assumption, but it has not been "proven" in the true sense of the word to this day.

On the other hand, a gravitational oscillation emanating from the fixed stars is an almost familiar idea to modern science. At the 1969 physics conference in Salzburg, it became clear that questions of gravitation are now more than ever at the center of scientific interest.

A gravity experiment by the American professor Jo Weber in particular forced us to examine gravity and the associated concepts. The FAZ newspaper of October 8, 1969 reported on this: "Professor Jo Weber's gravitational experiment is the first experimental proof of gravitational interactions, which until recently were considered practically unprovable because they are so weak. Almost exactly 10 years ago, Weber, who works at the University of Maryland in the USA, caused quite a stir in specialist circles with an award-winning theoretical paper. In it, he showed that it should be possible in principle to build a detector that is set into resonance oscillations by gravitational waves. Weber has now built such detectors and they do indeed seem to respond."

However, the origin of the oscillation is still unknown. Attention is mainly focused on fixed stars and fixed star systems, but since modern astronomy has rather grotesque ideas about these areas of space compared to the inner world theory, the correct knowledge to solve the problem is probably still a long way off. Ideas about collapsing star systems at unimaginably great distances, quasars and pulsars dominate the discussion.

The true scientist is well aware that true knowledge cannot be forced upon man.

In summary, we can say: Both the phenomenon of inertia of matter and of gravity are visible expressions of an interaction between matter and ether. Neither inertia nor gravity are properties of matter alone, as is often presented by modern science.

The dynamic and static cohesion of the material cosmos is caused by the interaction of inertial and gravitational forces. The cause of gravity can be explained by an ether vibration that is emitted by the sphere of fixed stars and that spreads along curved paths according to the spatial metrics of the inner world theory. This idea is only possible according to the inner world theory, since the Copernican theory does not recognize a world center as the source of an ether vibration. The inner world theory thus leads to completely new and surprising aspects regarding the still unsolved mysteries of gravity and the inertia of matter.

NEWTON'S CELESTIAL MECHANICS IN THE INNER WORLD THEORY THE ORBITS OF MOONS AND SATELLITES.

Before the launch of the first Russian satellite, Sputnik 1, in 1958, it was predicted that the attempt would result in a 76

The attempt to put artificial satellites into Earth orbit would fail if the inner world theory were a reality.

Because, it was argued, the centrifugal force would immediately cause the satellites to crash into the earth's hollow, round shell. The satellites were put into circular orbits and circled for weeks, months and years! If these predictors had been physicists and had studied Newton's celestial mechanics, they would have been able to see that the flight of the satellites could not be proof against the inner world theory or proof of the correctness of the Copernican system.

The possibility of placing artificial Earth satellites into orbit around the Earth is just as obvious from the mathematical foundations of the inner world theory as it is from the foundations of the Copernican theory.

In order to understand this in the case of the hollow Earth body, the following consideration is necessary: A body that moves in space without the influence of any forces (i.e. force-free) follows a curved path that is predetermined by the curved space metric (see section 2 The metric of space).

From now on, such a path shall be called a metric path (or metric curve or metric line).

This is a new term that is introduced here.

A metric line as the path of a force-free body is thus identical to the path of a light ray and a gravitational field line. This is the triple identity of Section 2, without which the inner world theory would not be tenable. Metric lines always run towards the center of the world (see Figure 23). All bodies moving without forces, as well as light corpuscles, therefore move on metric paths towards the center of the world. In order for a moving body to leave such a path, a force must act on it that pulls it out of this path, so to speak. This conclusion from the previous sections is, incidentally, nothing other than Galileo's law of inertia in a transformed form (see Section 1).

Following this consideration, the circular orbits of the moon and artificial earth satellites around the hollow, round earth shell can now be understood.

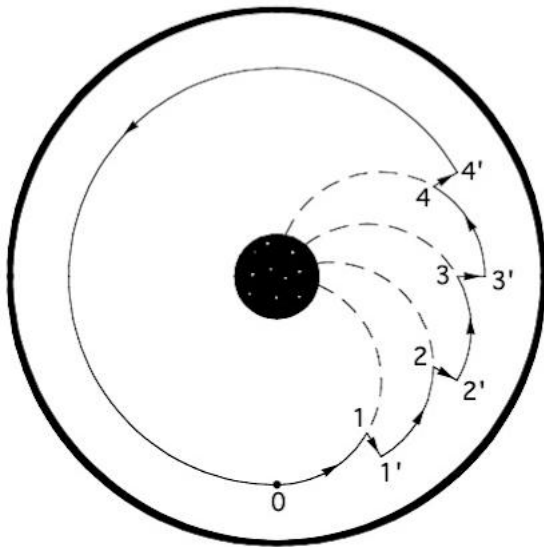

The orbit of an Earth satellite (and of the Earth's moon) can be understood as a continuous falling motion towards the Earth.

For this purpose, the orbit of an Earth satellite is divided into two parts in Figure 32. The satellite moves in a certain short period of time (e.g. 10 minutes) without the effect of the Earth's gravity, i.e. without any forces, on a metric orbit from point 0 to point 1. This orbit is therefore curved upwards just like a ray of light.

Now, however, in the same time (i.e. in the same 10 minutes), it performs a falling movement towards the Earth, since the gravitational force of the Earth's shell also acts on it (see section 4).

In the same time, it travels the path from point 1 to point 1'. After 10 minutes, the satellite has flown from point 0 to point 1', obviously on a direct path, i.e. on its circular orbit. The Earth's gravity pulls the satellite out of a metric orbit and forces it into its actual circular orbit.

Fig. 32

(The division into the force-free partial path and the fall path is of course only a mental aid, as is often used in natural science.) In exactly the same way, the further course of the trajectory can now be determined mentally:

The satellite "reaches" without any force on a metric curve 1' to 2 and at the same time falls from 2 to 2', etc.

In reality, the satellite does not reach points 1, 2, 3, 4, but moves in a circular orbit through points 1', 2', 3', 4'... and thus completes its orbit around the earth. The circular orbit of a satellite can therefore be understood as a superposition of two movements: firstly, an ascending movement along a metric curve towards the centre of the world (according to the curved structure of space) and a continuous falling movement towards the earth (as a result of the earth's gravity).

If the satellite is to describe an exact circular orbit, both partial movements must be precisely coordinated. Suppose the satellite flies too slowly. Then the fall path in a certain time interval is greater than the ascent path in the same time interval. The satellite approaches the earth's surface and sinks. If, on the other hand, its speed is too high, the ascent path in the time interval under consideration exceeds the fall path and the satellite rises. It is a difficulty in the 2003 Helmut I Diehl 77

Space technology is used to bring a satellite at a certain altitude to exactly this critical speed. If its speed is higher (supercritical), it rises; if it is lower (subcritical), it sinks.

The orbit of the Earth's moon is explained in the same way. It also orbits the Earth, but significantly higher than an artificial satellite. Its orbit is also determined by the curved space metric of the cosmos and by the gravitational force of the Earth's shell, which is still strong enough at the height of the Moon's orbit to bind the Moon to the Earth. The Moon therefore moves in the Earth's gravitational field.

The orbits of the other planets, however, are determined by the sun. They move in the sun's gravitational field and are practically no longer influenced by the earth's gravitational field, as will be explained in more detail later. Before that, however, the previous explanations will be explained in more detail using the example of a somewhat complicated satellite orbit.

Figure 33 shows the orbit of an "eccentric" satellite in the gravitational field of the Earth's shell. In contrast to Figure 34, where the height above the Earth's shell does not change. The satellite moves in the gravitational field of the Earth's shell, whose field lines run radially towards the center of the world (see section Gravity and Gravitation).

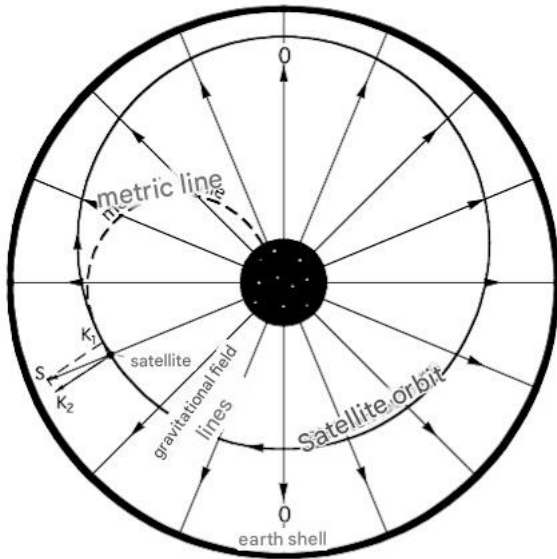

Gravity  $S$  acts on the satellite (it always acts in the direction of the gravitational field lines)

If this force were not present, the satellite would rise along a metric orbit towards the center of the world. How does the existing force  $S$  change the trajectory? To answer such a question, in physics the force  $S$  is broken down into components in the direction of the orbit  $K_1$ , and perpendicular to it  $K_2$ . The force  $K_2$  pulls the satellite away from the metric orbit and directs it onto its actual orbit, the force  $K_1$ , accelerates it on its orbit.

It therefore speeds up and gains kinetic energy as it falls towards the Earth's shell. At the lowest point  $U$ , its speed is supercritical, so it rises again.

In the process, it gradually uses up its supply of kinetic energy and slows down. At the highest point  $O$  it has its lowest (subcritical) speed. Therefore it begins to sink again, i.e. to fall towards the Earth's shell, etc.

....

Fig. 33

It is therefore a mistake to claim that satellites cannot orbit according to the inner world theory, since an outward-directed

Centrifugal force would cause them to crash onto the Earth's surface.

Such a centrifugal force does not exist at all. The orbit of an Earth satellite is an orbit that encircles the center of the world, a "cosmic orbit" so to speak. This is something completely different from, say, a stone that is swung around in a circle on a string. This latter case of circular motion is often viewed from the perspective of the balance of forces. Here, it is said that the outward-directed centrifugal force of the stone balances the inward-directed centripetal force of the string.

This approach is very useful in spatial areas with linear metrics. Every laboratory on earth is a very small space with a practically linear metric. The mathematical formulation of all laws of mechanics of moving bodies (dynamics) always refers to a linear spatial metric.

However, if the space metric is not linear in cosmic dimensions, then serious errors are made if the laws of mechanics are extended in this (linear) form to the entire universe. The result of these errors are contradictions of the type described above ("centrifugal force towards the Earth's shell"). However, such contradictions disappear completely if the laws are correctly transformed before they are applied to curved areas of space.

But there are also cosmic orbits that do not enclose the center of the world. An example of this is the orbit of an artificial satellite that orbits the Earth's moon. As is well known, the descent to the moon takes place from a circular parking orbit. In this orbit, the mother ship orbits the moon while the lunar module separates and descends to the moon. After the mission is completed, the lunar module climbs back into this parking orbit and the astronauts dock it again with the mother ship while it is still orbiting.

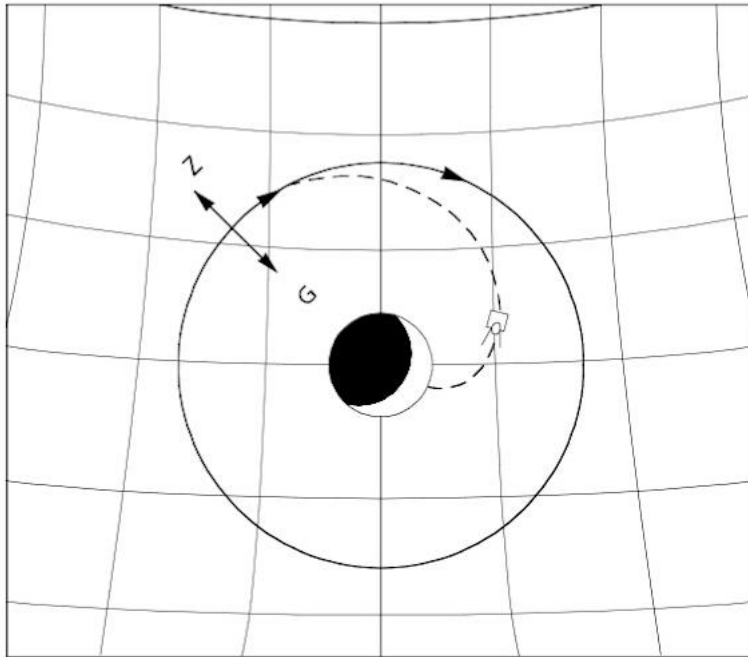

Fig. 34

An artificial moon satellite orbits in a region of space with an almost linear metric. Such a circular orbit around a celestial body takes place in a relatively small region of space, within which the spatial metric is almost linear (Fig. 34). The laws of mechanics in linear form are applicable here. Therefore, it is practical to use centrifugal force here too, which gives the same play of forces as with a stone that is swung in a circle on a string.

The centrifugal force  $Z$  is always directed outwards, away from the center of the moon. The gravitational force  $G$ , which acts on the satellite from the moon, always points towards the center of the moon. The outward-directed centrifugal force and the inward-directed gravitational force must be exactly the same size, then their effects cancel each other out and the spaceship moves in a circular orbit around the moon.

This is exactly how the orbits of natural moons around the planets are explained. As is well known, two such moons orbit the planet Mars, Jupiter has at least twelve moons and Saturn has

nine moons.

Moons and also dusty matter in the form of a ring, which can be seen with a telescope. The fact that such circular orbits around planets exist and are stable is explained by the inner world theory, just like the Copernican theory, as the interaction of centrifugal force and gravitational force.

It is important to see and understand this. The well-known objection that artificial Earth satellites could not orbit according to the inner world theory is based on the following argument: Since moons orbit the planets (this is an indisputable fact), there must also be a centrifugal force according to the inner world theory and this would immediately cause any Earth satellite to crash.

But this conclusion is wrong! Because on the one hand, one has to differentiate between small circular orbits that do not enclose the center of the world and large circular orbits that enclose the center of the world. The small circular orbits run in a relatively small area of space that has a linear structure. Here, the laws apply in the usual linear form. Here, we can speak of centrifugal forces. On the other hand, with the orbits that enclose the center of the world, the curvature of space comes into full effect and the laws of mechanics cannot be applied in the linear form. The centrifugal force does not appear here.

## Planetary orbits

### The Planetary System in Copernican Perspective

In the Copernican view, the sun is a central body orbited by satellites, the planets. Mercury orbits closest to the sun, followed by Venus, the earth (with the earth's moon), Mars, the asteroids (probably a destroyed planet), Jupiter, Saturn, Uranus, Neptune, Pluto and a suspected but not yet proven planet called Transpluto. That makes 11 planets if you count the asteroids. The diagram is shown in Fig. 35. The orbit radii are not drawn to scale!

According to the Copernican theory, the planetary orbits are ellipses and not circles, as shown here. However, the eccentricity of the ellipses is so small for all planets except Mercury that the deviation from the circular orbit is barely visible to the eye.

When observing the planets, the following is noticeable: There are planets that are always close to the sun and can therefore only be seen in the morning or evening at sunrise or sunset. These are the two planets Mercury and Venus. With a telescope, you can see phases of these planets, just like the moon.

The Copernican theory calls them the "inner planets" because they orbit within the Earth's orbit around the Sun.

The other planets can always be seen at any point in the night sky along the ecliptic. In the Copernican system they orbit outside the Earth's orbit and are therefore called "outer planets". They do not show phases, i.e. in the telescope they always appear as a fully illuminated disk.

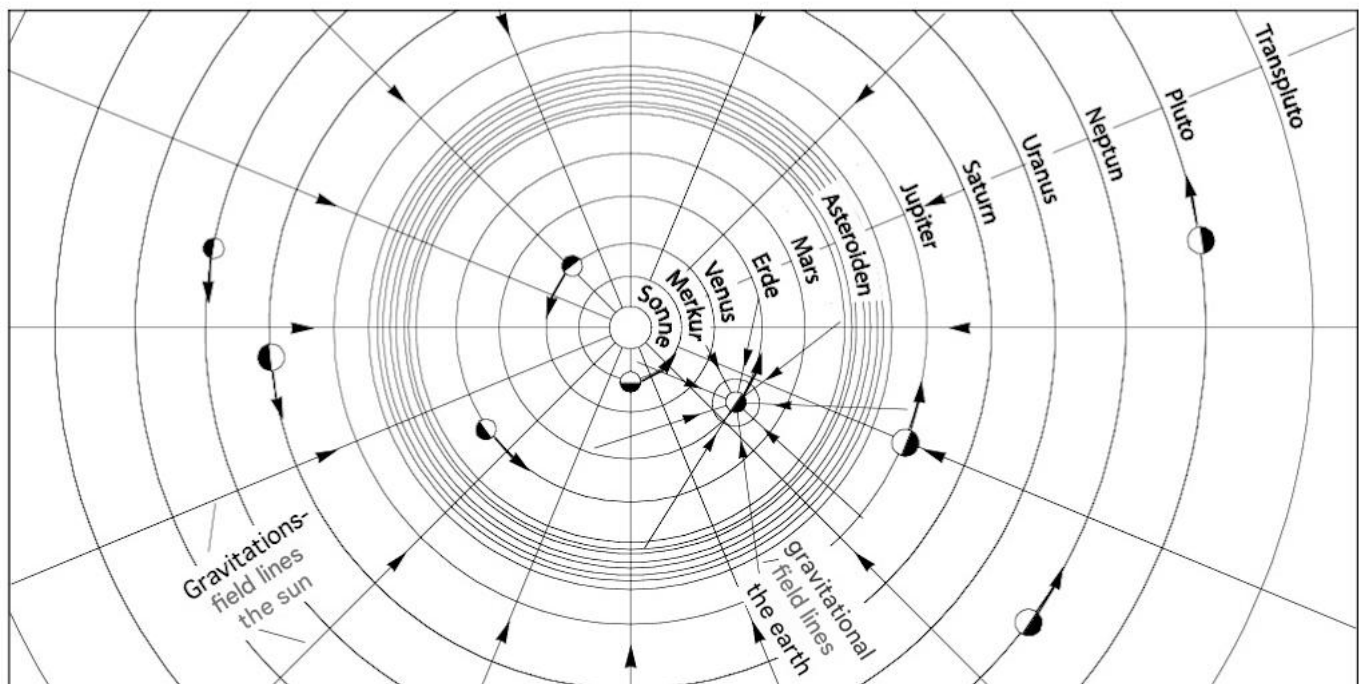

Fig. 35 The planetary system in the Copernican world view.

The planets are so far away that practically the same side that they face the sun is also seen from the earth. The inner world theory's explanation of the phase behavior of the planets follows later. It is just as simple and plausible as the Copernican explanation.



## The Curved Space Metric of the Inner World II

However, the planets Mercury, Venus, Mars, Jupiter and Saturn do not orbit the Earth, but the Sun. The Sun in turn carries the system of planets with it as it orbits the Earth. The planets therefore perform a compound movement: firstly, they orbit the Sun and secondly, with the Sun, they orbit the Earth. This is how the planetary loops come about. The planets actually move through these loops and are not an optical phenomenon like in the Copernican system.

The whole sequence of movements is most easily understood if one keeps the earth in position in Figure 35 and keeps all other movements the same. The sun then circles around the earth in an annual rhythm and carries the entire rotating planetary system with it. The Tychonic system is thus identical to the Copernican system, with only the reference point for all movements being moved from the sun to the earth. From today's point of view of the latest scientific findings, it is completely pointless to argue about whether the Copernican or the Tychonic principle is the correct one. Albert Einstein has shown that a specific reference point in space cannot be found relative to which all movements can be measured. Rather, it depends solely on the relative movements of the celestial bodies to one another.

However, this principle of relativity in modern science was discovered by looking at the universe in a linear way, that is, by considering light rays and the paths of force-free bodies as well as lines of force as straight lines. The curvature of space in the general theory of relativity is not mentioned here, because our considerations only refer to the planetary system.

However, this linear way of looking at things has always been used, from the beginnings of cosmology in ancient Greece through Hipparchus, Ptolemy, Copernicus, Kepler, Newton to the present day; because these "linear glasses" have never been discarded, and linear space metrics have not even been considered worth mentioning, but have been placed at the beginning of all theory as a matter of course.

Seen in this way, the choice of a reference point, the sun or the earth, is purely a question of expediency and so the geocentric Tychonic system of planetary motion has been retroactively fully justified and justified by modern natural science. The inner world theory is now the exact transformation of this Tychonic system according to the principle of "reciprocal radii". >

The earth's shell becomes the outer boundary, the fixed star world becomes the center of the universe as a fixed star sphere. Here heaven and earth, i.e. the fixed star sphere and the earth's shell, become a reference system.

This raises the important question:

How does the process of planetary movement appear in the inner world system?

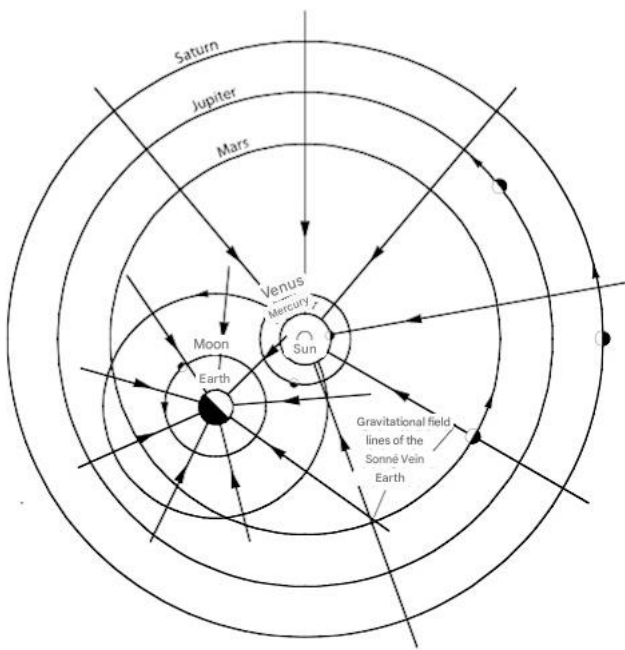

Fig. 36 The planetary system in the geocentric view of Tycho de Brahe

To do this, look at Figure 36. You can see that the sun and moon move around the earth in such a way that they always cross its gravitational field lines at right angles. However, when transformed by reciprocal radii, right angles are retained. If you take this into account, you can see that the sun and moon move in circular orbits (approximately) around the center of the world (see Figure 37).

However, since they move in the radial gravitational field of the Earth's shell, they are also bound to it in terms of forces. The orbits of the sun and moon are determined solely by the Earth's shell.

One must not imagine any gravitational pull between the sphere of fixed stars and the sun or moon! That would be a crucial mistake and would contradict all previous considerations!

There is indeed a small force of attraction between the sun and the moon, because all masses attract each other. But this force is small compared to the forces between the sun and the earth's shell, or the moon and the earth's shell. The fact that these latter forces are enormous can be seen in the tidal waves that the sun and moon create on the

earth's shell. The sun and moon also attract the earth's shell with the same force that the earth's shell attracts the sun or the moon, to which the easily moving water masses of the world's oceans react most easily and are piled up into tidal waves.

The orbits of the other planets are not determined by the Earth's shell, but by the Sun, as observation clearly shows. The planets Mercury and Venus are always close to the Sun, and are therefore companions to the Sun, as explained above.

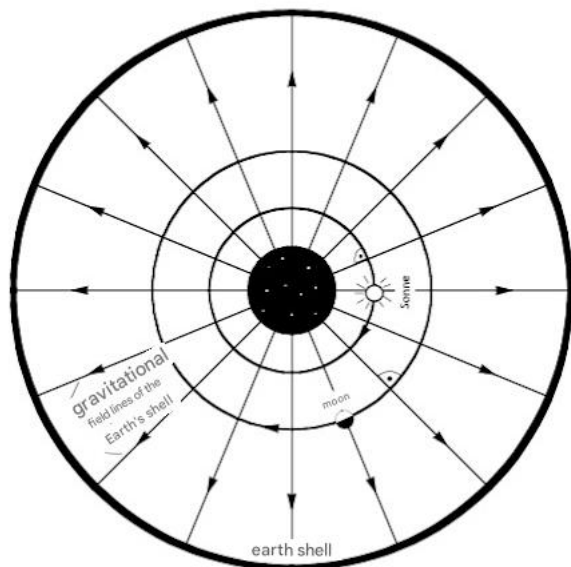

Fig. 37 The orbits of the Sun and the Moon are determined by the radial force field of the Earth's shell.

The fact that the other planetary orbits are also determined by the sun can be deduced from the fact that loops form. These loops form exactly in the annual rhythm, which proves that the planets are coupled to the sun. This fact is also taken into account in the Tychonic system and must therefore also be incorporated into the inner world theory.

If one now plots the gravitational field lines of the sun according to the inner world theory, one can determine the possible planetary orbits if one assumes that the planets always cross these field lines perpendicularly, as in Figure 38.

This way you can recognize two types of tracks.

One type includes the planets that orbit the sun, namely Mercury and Venus. These are the inner planets of the Copernican theory.

There they are "inside" because they are closest to the sun and orbit it as their center.

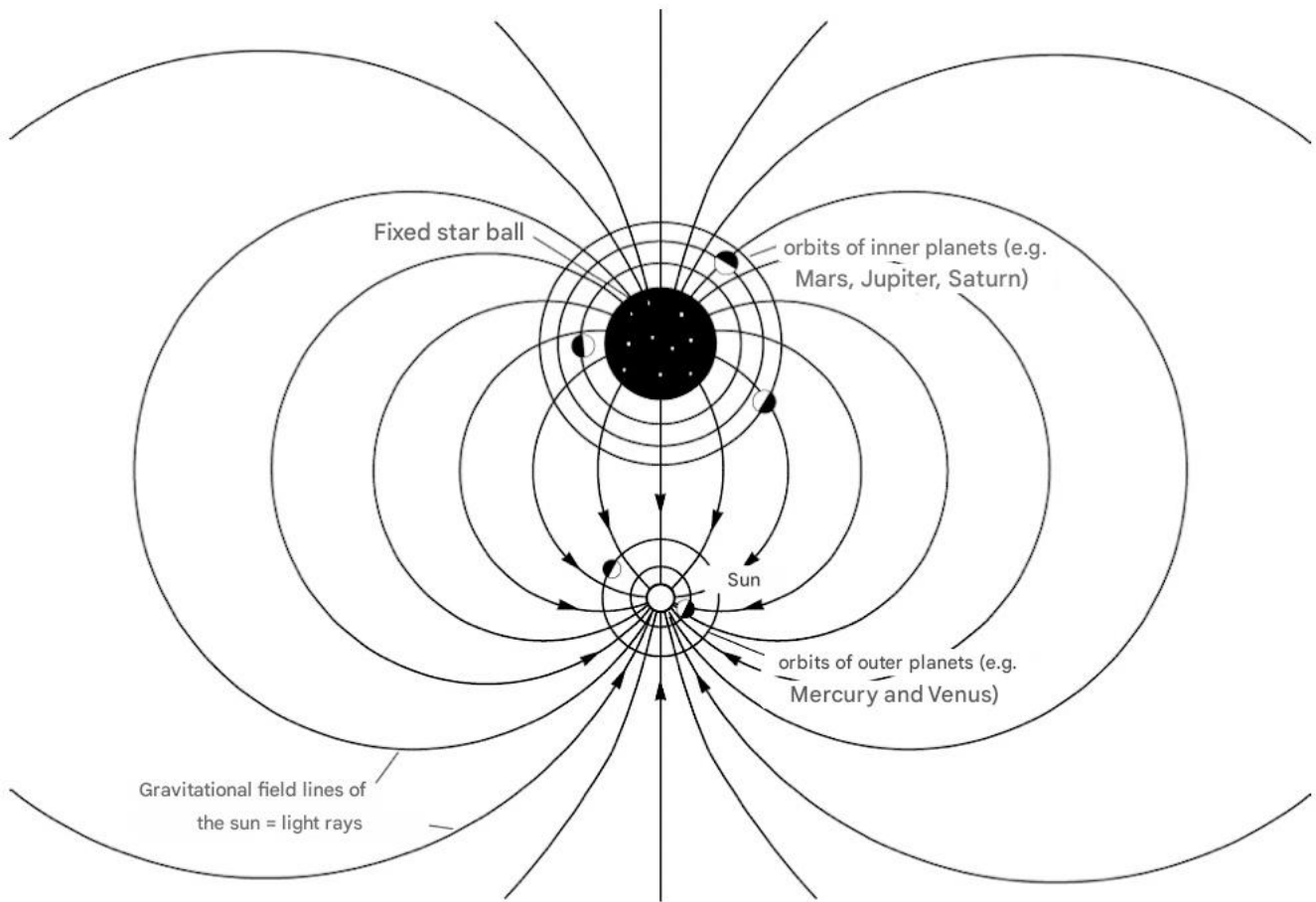

Fig. 38 The orbits of the inner and outer planets from the perspective of the inner world theory.

All planets move in such a way that their orbits intersect the gravitational field lines of the sun almost perpendicularly. The planetary orbits are determined by the force field of the sun.

According to the inner world theory, the center is the sky or the sphere of fixed stars. The sun is outside this center. Therefore, according to the inner world theory, the sun's companions Mercury and Venus are outer planets. The other type includes the planets that orbit the celestial sphere. These are the asteroids, Mars, Jupiter, Saturn, Uranus, Neptune, Pluto. These are the outer planets according to Copernican theory, but the inner planets according to the inner world theory. Pluto is the innermost of these planets. It is closest to the sphere of fixed stars.

The division into inner and outer planets is therefore also necessary according to the inner world theory, and is even more obvious when one compares figures 35 and 38. What should be noted is the interchange of the terms "outer and inner" according to the inner world theory compared to the Copernican theory.

The fact that the outer planets (Mercury and Venus) show changing phases, while the inner planets do not, is easily explained according to the inner world theory. If you look at the light rays emitted by the sun in Figure 38, you can see that these rays always hit the inner planets on the side that faces away from the sphere of fixed stars. But from the Earth's shell you can see precisely this side of the planet facing away from the sky. That is why the terrestrial observer always sees the fully illuminated half of the inner planets. A "waxing half Jupiter", for example, can never be observed from the Earth's shell.

This is the explanation according to the inner world theory for why the inner planets do not show phases.

The outer planets, on the other hand, show phases. The explanation is easy to find: the outer planet Venus, for example, can sometimes be exactly between the sun and the earth's shell. An observer on the earth's shell then looks at the unlit side of the planet.

This is the "New Venus" phase. After half an orbit, this planet comes to rest above the sun. Then you look at the fully illuminated side of the planet. It is "Full Venus". All the other waxing and waning phases lie in between. Exactly the same applies to the second outer planet, Mercury. This is the inner world theory's explanation for why the outer planets show phases.

An example will now expand the previous explanations and make them more understandable and deepen the knowledge gained. It shows how Newton's celestial mechanics, in a transformed form, also finds its way into the inner world theory. 2003 Helmut I Diehl 83

have validity

To do this, we consider the orbit of a planet that moves in the gravitational field of the Sun and does not intersect the gravitational field lines perpendicularly (Figure 39).

The force  $K$  acts on it in the direction of the gravitational field lines. This is the attraction of the sun. Without its presence, the planet would rise towards the center of the world, moving without force on a metric orbit.

What influence does the force  $K$  have? To answer such a question, in physics,  $K$  is broken down into components in the direction of the orbit  $K_1$  and perpendicular to it  $K_2$ . The force  $K$  now pulls the planet away from the metric line and directs it into its actual orbit. The force  $K$  accelerates it on its orbit.

Anyone familiar with the technique of force decomposition will immediately recognize that the force  $K$ , is not present when the planet moves perpendicular to the gravitational field lines, and that the force  $K_2$  is then identical to the force of attraction  $K$ . The planet then moves at a constant speed on its orbit (no acceleration, since  $K_1 = 0$ ). This is the case for most planets. In contrast, the orbits of asteroids and comets are such that they intersect the gravitational field lines of the sun at a very angle. They therefore also experience strong accelerations or decelerations on their orbits. They are accelerated on the part of their orbit on which they approach the sun.

They then plunge towards the sun, gaining a lot of kinetic energy in the process, but then "fall" past the sun and move away from it again like a hurled stone. On this part of their orbit they slow down again because they are slowed down by the sun. Consuming the kinetic energy they gained earlier, they then swing around the celestial sphere until they plunge towards the sun again.

The movement of planets and comets and other bodies in space is therefore the result of a grandiose interplay of various forces that grow out of the etheric sea and attack the moving bodies and force them into orbits. These orbits are not arbitrary, but are predetermined according to cause and effect, according to the strict laws of celestial mechanics. The whole thing is like a cosmic ball game.

A thrown ball follows a path that is determined by exactly the same laws as the path of the celestial bodies. The metric lines here are straight lines (because of their shortness). The gravitational force comes from the earth's shell. A flight to the moon is also in principle a throw. But here two gravitational fields have to be taken into account, namely that of the earth's shell and that of the moon. A "throw to Venus" takes place in four times the gravitational field of the earth, moon, sun and Venus.

## The Bipolarity of the Cosmos According to the Inner World Theory

An important result of the inner world theory is the realization of the bipolarity of the cosmos. The universe has two poles or centers (Figure 38). One pole is the fixed star sphere with the fixed stars and the sources of the gravitational oscillation (see Figure 26). This oscillation is the cause of the gravitational forces between all masses. These forces in turn create the planets and other

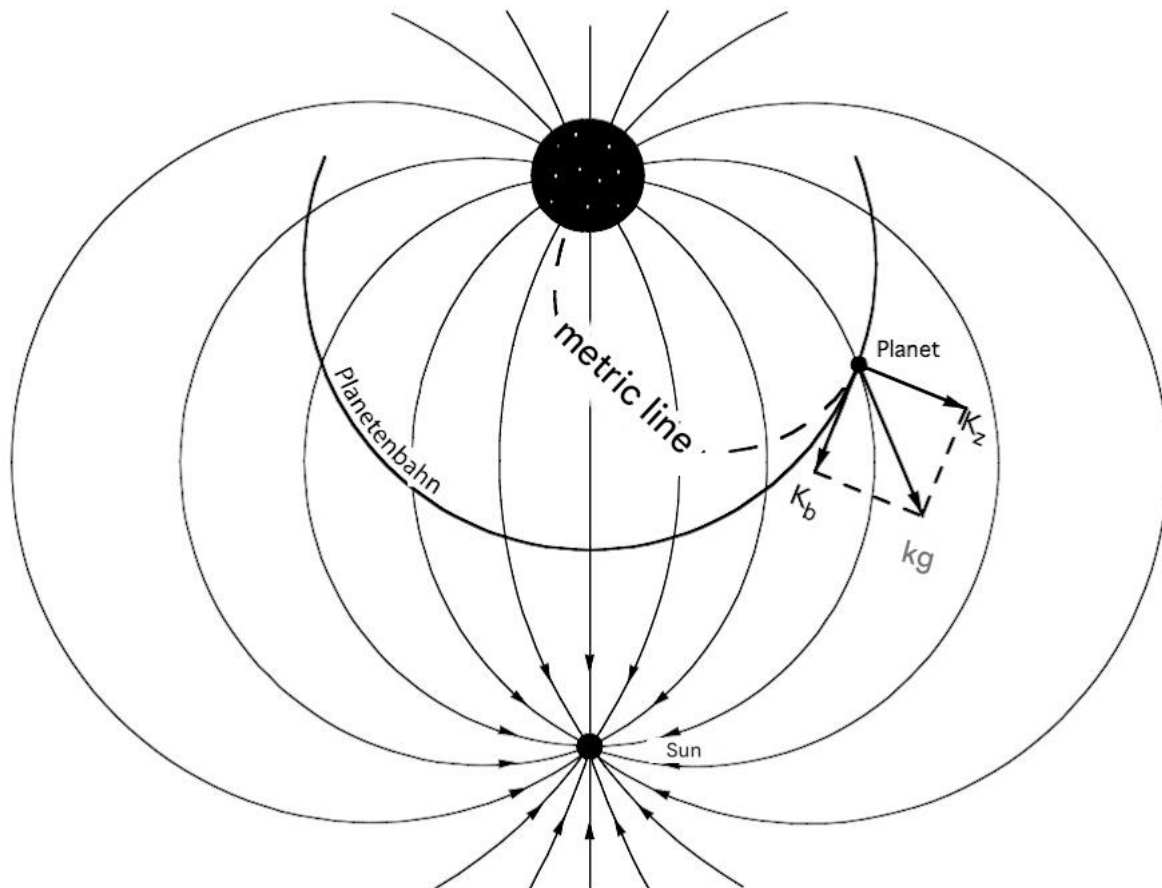

Fig. 39 Forces acting on a planet in the gravitational field of the Sun

Masses are accelerated and decelerated in space and thus guided along certain paths through (curved) space. The cohesion of the masses that form the Earth's shell and the hollow shells of the planets is also ensured by gravitational forces.

### Controlling the forces of the cosmos

If the sources of gravity dry up, the planets will fall from their orbits, the Earth's shell will dissolve into its components and the entire cosmos will collapse.

A physicist who studies the inner world theory can talk about physical effects when he recognizes that the two poles, the fixed star sphere and the sun, connected by their force field, control the material part of the cosmos and what forces emanate from them and how they work. Anyone who knows nothing about these cosmic power centers has no starting point for researching these forces. Of course, the cosmos is not only material, but as an organic structure it is as complicated and diverse as any organism, be it very small or very large.

Here, great secrets await the researcher to discover.

One of these two poles, the sphere of fixed stars, is the seat of the active, controlling and sustaining forces from which the entire inner cohesion of the material cosmos emanates. Of course, the sphere of fixed stars is the seat of many other organs and forces, also related to the spiritual realm of the organism cosmos.

The second pole is the sun. It is the main source of light and energy in the cosmos and on the other hand it forms the 2003 Helmut I

Center of the planetary family. The planets move in their gravitational field. The orbits of all planets (including the inner ones) are governed by their mass effect.

As it moves around the celestial sphere in the gravitational field of the Earth's shell, it carries the entire planetary system along its orbit. This movement results in the planets forming loops. In the Copernican world view, the planetary loops are an optical phenomenon, but according to the inner world theory, the planets actually move through the loops. This bipolarity of the universe is only visible according to the inner world theory. It cannot be seen in the Copernican theory. (Compare Figure 38 with Figure 35).

The bipolarity has its counterpart in everything organic and conceptual, including philosophy and religion.

Here we have the inner world theory and the resulting model of the cosmos that go beyond the mathematical and physical. It far exceeds the limits of what a predominantly mathematical-physical model of the cosmos can achieve.

As useful as the Copernican model of the world is in many practical matters, including space travel, it does not provide any answers for the thoughtful person in essential matters, such as the philosophical questions about the meaning of life, about heaven, about the creator of the world. It shows us the heavens as absolute emptiness and the earth as nothingness.

The inner world theory, however, shows heaven as the center of the universe, and the major religions that are part of the cultural heritage of humanity teach that the throne of the divine is there.

The earth is the unique and important basis for the preservation of organic life.

And that answers the question that is often asked:

Is this new world view of the inner world theory actually necessary?

Why a further development of the astronomical system developed by Copernicus, Kepler, Brahe and Newton was necessary.

Does not the Copernican theory rest on the iron foundations of internal coherence and resistance to practical application?

Yes, all of this is undisputed. But this system has one crucial disadvantage. It is silent and fails completely when it comes to the question of the meaning of our existence and also when it comes to the central ethical questions of our time.

Therefore, it can be neither more nor less than what it should be and was from the beginning:

An excellent computational model.

But organic reality is different! To recognize this, one must leave the linear, mathematical way of thinking in order to develop new research results with the help of new knowledge, expanded mathematical-physical thinking, and the help of curved spatial metrics.

This step leads via transformation to the inner world theory, and this theory is not in opposition to the Copernican theory, but rather is its organic and logical further development. It is therefore not a revolutionary theory, but an evolutionary one. It builds on the old, the grown and the proven, connects what belongs together and crosses the border to new, spiritual spaces of human knowledge.

## The loss of reality and the divine center

A philosophical reflection, edited by Helmut Diehl

The Christian Bible begins with the sentence: "In the beginning God created heaven and earth. Intellectually gifted people think they know the earth and the essentials about the earth's body. But do they also know that the earth was designed according to the proven principles of creation, like everything that God created, namely according to the principles and form of a biological cell?"

This principle, applied to all form creation, means that every form that occurs in nature and that man copies is made according to the basic pattern of the cell: This means, therefore, that a space is formed with the help of a protective shell with at least two openings, one of which serves for ingestion and the other for excretion. There is no deviation from this principle, regardless of whether it is a creation of God, a structure of inorganic nature, or whether a technical structure occupies only one space. The space thus gained or allocated is equipped with organs or devices serving the purpose of the structure in such a way that a mediating fluid connects everything between the organs or devices through a circuit.

The protective and limiting shell with its closable openings connects this structure with the outside world for metabolism.

This applies from the smallest individual structure to the largest all-encompassing structure or creature, the Cosmos.

All inorganic or technical structures are internally pulsated by a circuit whose energy is supplied from the outside. Only organic structures have a cell nucleus eccentrically in the middle of their interior, which identifies this structure as a living being. This cell nucleus controls the typical functions of biology and, via the internal circuits, controls the survival of the body formed from bio-cells, all movements, the healing processes and the regrowth of damaged organ parts, and carries within itself the ability to reproduce.

Everything that happens, all life expressions of the shell and the interior are directed towards the cell nucleus and all life-sustaining functions of the cell nucleus are directed towards the organic processes in the interior and the shell. In addition, the cell nucleus has nerve connections via the inner sensory organs to the outside of the living being in order to be able to face external dangers. A memory records the events and enables

Memory is a logical and correct behavior for protection through defense or flight.

What is given to the smallest living creature in this way proven by experience by the Creator of the whole, or the preserving forces of nature, must logically also be expected of the structure of the whole, i.e. the cosmos. Anyone who contradicts this is acting against experience in reality and would have to have a very good reason why they would deviate from the wisdom of the form and function that prevails in nature.

All reality speaks against it.

Nevertheless, theoretical science has deviated from this formal principle and thus from observed reality.

Why did this happen?

The natural philosopher Gustav Portig (10) gives the following information in his book: The universal law of the least expenditure of force in the kingdoms of nature. Part I on pages (3-10 and 17-20):

"It is both a strength and a weakness of human reason that it can and must reduce the immense multiplicity of things and events to majorities, and then reduce these to a single unit or as few as possible. This procedure is necessary so that it can master all impressions and ideas and assert its own unity and independence in relation to them. Since the human ego knows itself immediately and always as a unity, it is under the compulsion to understand the world as a unity too.

The soul of a higher animal is capable of forming ideas from sensory impressions and of making a very limited selection from these. The reason of the human spirit, on the other hand, is capable of forming concepts from related ideas, and from these, ideas. It seeks to understand all given connections between events as lawful, according to causes and effects, according to reasons and consequences. Reason fuses all its concepts, ideas and laws into the unity of a formally harmonious and materially satisfying whole human being.  
world view.

This world view, gained through the 'way of ascending procedure', can then be used again by the human mind as a secure 2003 Helmut I Diehl

Scouts use it to explore unknown areas.

Insofar as this enormous work was carried out in prehistoric times as a work of the unconscious national spirit, the individual receives its reflection in language. All concepts in a language are the result of more or less complicated crystallization processes through which something multiple has been unified. All language formation can only ever progress from given views to concepts which human reason carries out of its own power according to an inherent law and root concepts resting within it. The same path which the unconscious national spirit once took in the formation of language must be followed again and again by the conscious mind of the individual if it wants to form for itself a life and, beyond that, a world view as the acquisition and the dominant basic motive of its entire activity. Just as there can only ever be individual, unambiguous, not ambiguous truths, there can ultimately only be a single, internally unified and satisfactory world view which emerges as a unification from the total material of experience over thousands of years.

All concepts, ideas and laws that have emerged from unifications together form the realm of logical and mathematical possibility. This must be derived from the realm of given reality through inner and outer experience, but then acquire a meaning in itself, because the thinking of reason has proven itself to be relatively productive in it.

The realm of (logical) possibility can and should be derived from that of reality; the reverse procedure, however, is inadmissible.

It is a self-deception born of convenience to try to spin out this realm of possibility from human reason alone and then to use a few facts from reality as supposed evidence. The only right thing to do is to collect the rich material of experience through hopeful work and humble self-denial, to organize it critically and, on this secure basis, to slowly climb up to a world view that may be incomplete but is capable of being expanded and perfected.

It is presumptuous to want to determine or even create reality based on merely imagined possibilities.

Rather, the only worthy task of philosophy remains that, through the most extensive and correct unification of the entire world of experience, a basic experience arises which has a reality and necessity in its own way, just as the world of substance has its own.

But one worldview can also be built with the help of the lower faculty of the intellect, and another with the help of the higher insight of reason. In the individual human being, as in the development of civilized humanity, the lower faculty precedes the higher. If that is correct, then the worldviews developed by both faculties must also differ in rank and value. And in fact, this is also shown when comparing the two systems of thought (worldviews). The intellect can only ever reach a final simplification through continual separation; reason reaches unification through fusion. In both cases, a "unity" takes place; but the process and the result are opposite.

The mind either combines details into a sum, or, conversely, it breaks a sum down into its parts. Its ideal must be to arrive at nothing but similar particles, and then conceptually grasp their sum as the simplest unit. It achieves its logical abstractions through ever-increasing separation, dissolution and dilution. It separates by differentiating, it breaks down everything individual in order to discover a conceptual general behind and above it; it unifies the generalizations it has achieved until it finally arrives at the most general as the simplest in itself. It thus masters the enormous multiplicity of things and events by destroying their reality in order to retain a shadow image of them as the supposed essence of all being.

Whether the intellect, in the work of its simplification, ultimately considers itself to be philosophical reason because it arrives at a primal idea, a primal law or a primal substance, and therefore always at a one, this does not change the essence of the matter. But after it has achieved its ultimate goal through continued negation, it suddenly makes this its highest. From this it then lets the same world emerge again by the power of a logical-dialectical or mathematical mechanism, which it had previously diluted to the utmost simplicity. Just as a fan unfolds and folds up again, so too does the world process here; just as the two halves of the major scale, a symmetrical building, a fountain, a column rotating to the right and left correspond to each other in chemistry, so do the ascending and descending halves of the world process. This game of tag by the intellect with its own shadows could be left to it if it did not think of trying to master the realm of reality from them.

He now boldly claims that there is certainty only in the realm of his logical and mathematical possibilities, while the realm of reality leads only to probabilities. Formal correctness is more important to him than the material content of what we ultimately recognize as truth. Just as theology once used philosophy only as a tool for certain arguments; just as aesthetics, well into the 19th century, treated art history only as a collection of examples, and mathematics in the form of theoretical physics still does today.



The philosophy of pure understanding also treats the content of the historical and natural sciences only as material for its own essential simplifications.

But the striving of the mind for the greatest possible simplification is exactly the same, regardless of whether it occurs in philosophy or theology, in mathematics or the natural sciences. The basic precondition is always that the mind wants to gain a supposedly ultimate result under the name of reason, which it then places back to the beginning. Once in possession of this simplest and ultimate result, it then conjures up the whole of reality from it. Theoretical physics is still a striking example of how this happens today. It develops its laws by means of mathematical proof, and it can achieve great things if the physicist incorporates the right prerequisites into the approach he has to find. Either he has received these in a visual way of thinking, like Helmholtz in his formula for the principle of the smallest measure of force, or Maxwell in the basic equations of his electromagnetic theory of light, or Max Planck in his original formulas for the nature of space and time, mass and temperature (1899). Or he has taken correct facts from the reality known up to that point and put them into the form of a new problem. If physicists, as is often the case, make different approaches to one and the same problem and introduce false assumptions, the answer sought, i.e. the development of the equations, also contains errors and fallacies. In addition, higher mathematics is also based on assumptions of a purely philosophical nature, which the mind has previously taken directly or indirectly from a piece of the given reality and transformed for its own purposes.

Now, it cannot be said clearly and often enough about natural science that through all logical and mathematical conclusions one can arrive at an imaginary consistency, but not at a prediction of reality.

A deeper study reveals that natural science is full of hypotheses. The truly important leaders of the individual disciplines also recognize this; only the second and third rank figures deceive first themselves and then others when they present what is only conjecture as scientific truth in the blink of an eye.

or, at best, a fragment of a truth. It is precisely those natural scientists who are mere orphans in terms of their own philosophizing who most brazenly attack philosophy. They cannot even think logically correctly, let alone be capable of metaphysics. In the last 50 years (from 1850), natural science has assumed the aura of infallibility just as orthodox theology and philosophy did before. When the rising generation begins to realize this, then woe betide those little popes! Either there is an orthodox, divinely inspired dogmatics, or there is a historical-genetic, critical, humble science.

If the appointed representatives of the latter want to switch roles with the former, then without a doubt the Roman Catholic Church is the greatest mechanism, and its infallible Pope is a hundred times preferable to the worm-eaten carnival heroes of the worshiped abstraction "science".

Thank God! We now finally have the beginning of a new series of facts on which we can base a more reliable world view than the one we have had so far. But only if we humbly pursue the given reality does it appear to us in all its greatness. It was the false megalomania of the intellect when Leibniz once wanted to dissolve philosophy into mathematics and logic, just as today people want to dissolve philosophy into psychophysics. It was a somersault of logic when Kant wanted to let the human mind dictate its laws to nature. It was the height of sleight of hand when Hegel used the supposed primal concept of Being-Nothing to unravel the same world process whose content he had first taken from reality.

But not only most philosophers, but also many natural scientists are caught up in the delusion that the realm of logical and mathematical possibilities coincides with that of reality; that both run parallel to each other or even run as different mechanisms; that logical and mathematical formulas exhaust the entire content of reality. Here the shadow is thought of as being of the same kind as light, the tool and the sketch as being equal to the finished work of art. But it must finally become generally recognized that the realm of logical and mathematical possibilities is indeed quantitatively infinite, but that the realm of reality is one of individual determinations and unambiguous facts, and that a single, actually given determination has a higher value than a kaleidoscope of mere possibilities.

If the philosophizing mind wants to simplify the given reality to a final, most general and thin concept, then it is free to do so. But if it turns its last into the first and highest, and believes it can make the poorest into the richest, then one must call out to it: keep your hands off of it!

This generalization and simplification, which has been carried out to the last, has a certain value only insofar as it indirectly proves that man cannot and should not pursue true philosophy in this way.

This game of shadows, however, can easily lead to the illusion that the human mind is a creative force. This is dangerous because man does not need to make a personal moral decision in relation to his own ultimate dilutions and simplifications, as he does in relation to the living, self-confident God.

It is important to make the following truth clear to oneself as a fundamental one. All operations of the separating, simplifying understanding are under the control of the metaphysical primal concept of quantity, and this presupposes in reality the substantial individualities to which it can be applied. The understanding does indeed gain in extension through its simplifications what it loses in content; but it should never shrink from the recognition that unlimited extension is the ultimate goal. It is irrelevant to it whether this is the extension of the mere general possibility of existence or of the general substance. For it, both lie behind the individualities of reality. The philosophizing understanding may also be free to describe this most extreme of all its negations as "the absolute". The unconditional, the unlimited is, after all, only the greatest possible extension of a negation. It is absolutely correct that the most contentless extension, as a mere possibility of existence, must also be completely without relation, because every individualization of that primal concept also includes a finiteness, i.e. a narrowing of the most general negation.

But it is an atrocity that cannot be denounced sharply enough to transform the original negation into the original position in the twinkling of an eye, to transform the last possible thing into the original reality, the most imperfect thing into the absolute perfection.

If the world process begins and ends only with the emptiest of all negations, then it is itself only another form of illusion; then logical possibility and reality are only dilutions and condensations of one and the same something. Here the individuals are there for the sake of the world process, and this in turn has the purpose of proving through its self-dissolution that nothing truly exists except what is logically possible. Just as in mechanics potential energy can always be transformed into actual energy and vice versa; just as the entire natural process finally dissolves into the same general heat or non-heat: so there being disappears into nothingness.

The concept of the absolute only has value if the ultimate and highest is simultaneously thought of as the most perfect.

It is a contradiction in itself to try to make the most meaningful negation (the infinite) out of the last, most empty negation by simply reversing it. If the concept of quantity is the only, all-dominating, original concept, then philosophy only arrives at a negative, not a positive absolute.

In metaphysics, this limitless extension corresponds to space and time, because space is a resting, all-round extension, while time is a moving, one-sided extension. Within matter, it corresponds to the world ether, within the monism of the spirit, to the unconscious world soul. The limitless extension of the logical understanding is the general possibility of existence, from which all individual reality must be distinguished. However, the monistic worldview makes it into a general substance and as such is called "absolute", i.e. limitless. Of course, this can only be "unconscious"; when it becomes effective, it can only have itself as its object, and thus exists simultaneously in two different forms of itself. It forms a counterpart with itself (thesis-antithesis) when it separates; it forms a unity again (synthesis) when it withdraws into itself.

A name is now given to this so-called absolute, general, simple substance, which is taken from reality. It is either thought of as matter (formerly as substance [mass] and non-substance, as non-material force"; or more recently as ether, the next condensation of which is energy, the further condensation of which is substance); or finally as energy, the rarefaction of which is ether, the condensation of which is substance.

The other name taken from experience is that of the spirit."

At this point I interrupt the philosopher Portig because the research results have overtaken him in a positive sense, as it has now been 100 years since he published his book. What he particularly worked out is the relationship between quantity and quality. Quantities can be calculated mathematically with relative ease, but when it comes to qualities, extreme care is required, because we are dealing with different and usually higher values. Price usually expresses the higher value, but if it is not about money and price, how do you classify qualities? Love cannot be mathematically measured correctly with numbers, nor can it be bought with money, and yet it is one of the highest values. Feeling love, giving it and receiving it are abilities of varying degrees. What is this ability? It does not belong to the realm of the material, but to the realm of the soul and spirit, like so much of the realm of sensations, thoughts and the intellectual process.

Our experience with real events shows us that the spiritual and the material are complementary opposites that lead to something new through harmony.

The philosophy of ancient Egyptian civilization knew two sacred opposites of concepts that were considered divine: spirit and matter, space and time, from which the cosmos arose through the creative impulse of the creator god. See Professor Röth, (11).

This cosmos is our reality, which we create with our intellect of the brain, the intuition of the soul and the 2003 Helmut I Diehl 90

incoming gift of God (active among Christians as the gift of the Holy Spirit). We would fail if we did not use all three gifts in our attempt to recognize, describe and communicate this given reality.

This is why the philosopher Gustav Portig writes on pages 17-20 of his book: "In the history of the human mind, we have encountered a common basic feature in all areas in the most diverse forms over thousands of years. Reason is initially only able to understand the second member of a duality as another form of the first. It is not yet able to think of two original, independent, essentially different members simultaneously as a (harmonizing H.D.) unity. So we (today's ego-people) must also find our way from the age of the I and the non-I to the higher age of the I and you, from that of the counterpart of the one substance to the (harmonizing) opposition of the two substances, from (primitive) simplification (separation) to unification (connection), and from the all-dominating primal concept of quantity to one of quantity and quality as the duality in thinking. The final duality here is called God and the world, as (harmonizing) opposites, not as counterparts (separated from God).

Furthermore, of greatest importance is that the realm of conceptual logical and mathematical possibilities is recognized and acknowledged as essentially different from the realm of given reality.

The realm of possibility ultimately leads to simplification, that of reality to the most content-rich unification imaginable. Nothing real can ever emerge from something merely thought, thought never exhausts reality, reality can never be transformed back into a mere possibility. The realm of possibility can only be reduced to the smallest possible number of ideas, laws and principles, that of reality to the fewest possible quantities (substances) and (metaphysical) qualities. If there are two equally original substances as members of a primal opposite, then there are also two metaphysical qualities corresponding to them. No created substance can be reduced, let alone destroyed; no eternal truth can ever be invalidated, no deed can be undone.

What we can call the realm of metaphysical possibilities is only a unification of the given reality, a reduction to eternally necessary, unchanging principles. But it extends far beyond the realm of logical possibilities. The latter are quantitatively endless, but the principles are the mediator between God and the world. God and the world are bound to them; from them he let the original concepts and laws of the world process emerge for himself. This trinity of eternal principles has a reality in its own way, just as the realm of substances has in its own. If it did not have this, it could not form the basis of the world process of the cosmos.

By means of simplification we arrive at ever greater indeterminacy, by means of unification we arrive at ever greater determinacy. As in the latter case the ultimate indeterminacy can only be that of quantity, so here the highest determinacy is that of quality.

Quantity culminates in unlimited expansion, quality in the most limitless self-limitation. The former is the most negative reduction of power, the latter the most positive increase of power.

All things represent the innumerable possible combinations of quantity and quality. The more precisely individualized quantities are, the more they are open to the influx of qualities. The whole world process has no other purpose than to reverse the relationship of greater quantity and lesser quality originally established by God into one of the predominant quality in the world of spirit and matter.

We call a combination of quantities and qualities carried out down to the smallest and finest detail an individual. The whole of reality consists only of individuals, each of which has something irrational about it. But if even God and the world can only be thought of as individualities because they form the last and highest of all opposites, because they are the last possible most content-rich unification, then there is no general substance in reality, but only in the realm of concepts.

'Furthermore, if there are not two completely identical things or events in reality, then only unification, not simplification, will achieve the goal.

Simplification always destroys what has been conceived with infinite rational imagination and created with infinite creative enthusiasm: namely, the individualities of the universe. Unification, however, leads these up to higher potentials of themselves and increases the "urge to live" that is implanted in them. Mere indeterminacy and boundlessness end in an all-consuming abyss, unification raises everything up to ever more mature and higher life. The mere simplicity of quantity is empty, unification to ever purer quality is sublime. The understanding ultimately becomes arrogant through its simplifications because it alone still hovers above the darkness of the universal absolute; reason becomes ever more humble and at the same time more hopeful towards its unifications. When we say: philosophy is the non-ego of mathematics, that is the greatest imaginable simplification; but when we say: philosophy is the science of the whole of science, that is the greatest imaginable

greatest unification. If we say God is the Absolute, that is the worst dilution or emptying; but if we confess: God is love, that is the greatest possible enrichment through unification.

If, on the one hand, the entire universe consists of nothing but individualities, and on the other hand, nothing absolutely isolated occurs; if even the highest unification is that of the opposition between God and the world, then the highest metaphysical principle must be that of reciprocity or duality. On the one hand, there are as many differences as there are individualities, and on the other hand, every individuality exists only within a duality. In the whole of reality, every individuality is somehow composed, because it must simultaneously assert itself and surrender itself to another individuality.

Only in this way can they be effective. But they only really exist if the totality of all substantial individuals, which we call the world, can bring about something.

If they are not capable of this, they are only capable of movement or activity, i.e. capable of the appearance of effectiveness.

If the world process is to really have an effect, it must be based on duality, both of whose elements can effect something through their interaction." So says the natural philosopher Gustav Portig.

Let us now return to our statement that humanity has suffered the loss of reality and the divine center. This was made possible by the change from the geocentric world view with the earth in the middle and the sky behind the stars around 500 years ago. Now, in the heliocentric world view, it was considered theoretically correct that the sun was in the middle of the cosmos. At first, people accepted the idea of the sky behind the stars, but immediately gave up this idea of the sky when theoretical difficulties of a mathematical nature arose.

The philosophical interpretation of the cosmos as heaven and earth, which was correct in the Church's view, was thus called into question by the theory. The age of theoretical physics began with Copernicus and Galileo, with all its errors and successes. A misfortune for humanity was the lack of real scientists within the Church at that time who were able to defend reality and not instead threaten and use the stake, but who were also able to understand theoretical physics as an attempt to describe reality using the means of mathematics. They recognized, as Copernicus did at the beginning, that he was writing about a mathematical model of the cosmos. They also realized that this could not have endangered the reality of the real existing cosmos if reality and theoretical physics had been understood as harmonizing opposites, as is already partly possible today. The disaster took its course when theoretical physics was gradually taught as truth and reality by some of its philosophically uneducated representatives. The major figures among scientists did not commit this error, but the followers and zealots, by their sheer numbers, created the basis for the error to spread and for anyone who tried to correct it to be ridiculed.

As a witness I quote Professor Albert Einstein, who wrote the following:

Lecture by Professor Albert Einstein

If you want to learn something from theoretical physicists about the methods they use, I suggest you stick to the principle: do not listen to their words, but listen to their actions! For someone who invents, the products of his imagination appear so necessary and natural that he does not regard them as constructs of thought, but as given realities, and would like them to be regarded as such.

These words seem calculated to make you leave this lecture. For you will say to yourself: he is himself a constructive physicist and should therefore leave the reflection on the structure of theoretical science to the epistemologists.

From a personal point of view I can defend myself against such an objection by assuring that I have not climbed to this pulpit of my own accord, but on a friendly invitation, and that it is in memory of a man who has struggled all his life for the unity of knowledge. In fact, however, my efforts may be justified by the fact that it can be interesting to see how someone thinks about his science, who has spent a lifetime striving with all his strength to clarify and improve its foundations. The way in which he views the past and present of his field may depend too much on what he expects from the future and what he strives for in the present; but this will be the fate of everyone who has lived intensely in a world of ideas. He is like the historian, who also groups actual events, albeit perhaps unconsciously, around ideals that he has formed for himself with regard to human society. We will take a brief look at the development of the theoretical system, focusing our attention on the relationship between the theoretical content and the totality of empirical facts. This is the eternal opposition between the two inseparable components of our knowledge, empiricism and reason, in our field.

We revere ancient Greece as the cradle of Western science. Here, for the first time, the intellectual miracle of a logical system was created, the statements of which were so sharp that each of the theorems proved was beyond all doubt - Euclid's geometry. This admirable work of reason gave the human spirit the self-confidence for its later deeds. Anyone who is not inspired by this work in his youth was not born to be a theoretical researcher.

But in order to be ready for a science that encompasses reality, a second fundamental insight was required, which had not become common knowledge among philosophers until Kepler and Galileo. We cannot gain any knowledge about the world of experience through mere logical thinking; all knowledge about reality starts from experience and flows into it. Statements arrived at purely logically are completely empty with regard to reality. Through this insight and especially by hammering it into the scientific world, Galileo became the father of modern physics, indeed of modern natural science in general.

But if experience is the beginning and end of all our knowledge of reality, what is the role of reason in science?

A finished system of theoretical physics consists of concepts, basic laws that are supposed to apply to those concepts, and corollaries that can be derived by logical deduction. It is these corollaries that our individual experiences are supposed to correspond to; their logical derivation takes up almost all the printed pages in a theoretical book.

This is actually exactly the same as in Euclidean geometry, except that the basic laws there are called axioms and there is no talk of the corollaries being supposed to correspond to any kind of experience. However, if one understands Euclidean geometry as the theory of the possibilities of mutual positioning of practically rigid bodies, i.e. interprets it as a physical science and does not ignore its original empirical content, then the logical similarity of geometry and theoretical physics is complete.

We have now assigned reason and experience their place in the system of theoretical physics. Reason provides the structure of the system; the contents of experience and their mutual relationships are to be represented by the corollaries of the theory. The value and justification of the entire system and, in particular, of the concepts and fundamental laws underlying it lie solely in the possibility of such a representation. Moreover, the latter are free inventions of the human mind, which cannot be justified a priori either by the nature of the human mind or in any other way.

The fundamental concepts and laws that cannot be reduced logically form the inevitable, rationally incomprehensible part of the theory. The primary goal of all theory is to make those irreducible basic elements as simple and as few in number as possible.

possible without having to forego the accurate representation of any empirical content. The view outlined here of the purely fictitious nature of the foundations of the theory was by no means the dominant one in the 18th and 19th centuries. However, it is gaining more and more ground because the intellectual distance between the basic concepts and fundamental laws on the one hand and the consequences that are to be related to our experiences on the other hand increases more and more, the more the logical structure is unified, i.e. the fewer logically independent conceptual elements on which the entire structure can be based.

Newton, the first creator of a comprehensive, powerful system of theoretical physics, still believed that the basic concepts and laws of his system could be derived from experience. His phrase "hypotheses non fingo" should probably be interpreted in this sense.

In fact, at that time there seemed to be nothing problematic about the concepts of space and time. The concepts of mass, inertia and force and their legal connection seemed to be directly derived from experience. But once this basis is accepted, the expression for the force of gravity appears to be derivable from experience, and the same could be expected for the other forces.

### The fictional nature of Newton's system

We can see, however, from Newton's formulation that the concept of absolute space, which included that of absolute rest, caused him discomfort. He was aware of the fact that nothing in experience seemed to correspond to this latter concept. He also felt uneasy about the introduction of long-distance forces. But the enormous practical success of his theory may have prevented him and the physicists of the 18th and 19th centuries from recognizing the fictitious character of the foundations of his system.

The natural scientists of those times were rather mostly imbued with the idea that the basic concepts and laws of physics were not free inventions of the human mind in the logical sense, but that they could be derived from experiments by "abstraction" - i.e., in a logical way. The clear recognition of the incorrectness of this view was actually only brought about by the general theory of relativity; for this showed that with a foundation that differed greatly from Newton's one could do justice to the relevant range of empirical facts in a more satisfactory and complete manner than was possible with Newton's foundation. But quite apart from the question of superiority, the fictitious character of the foundations becomes completely evident by the fact that two essentially different foundations can be shown that largely agree with experience. In any case, this proves that any attempt to logically derive the basic concepts and laws of mechanics from elementary experience is doomed to failure.

If it is true that the axiomatic basis of theoretical physics cannot be derived from experience but must be freely invented, can we hope at all to find the right way? Even more. Does this right way not only exist in our illusion? Can we then hope to be safely guided by experience when there are theories such as classical mechanics that largely do justice to experience without grasping the matter in depth? To this I answer with all confidence that in my opinion there is a right way and that we can also find it. Based on our experience so far, we are justified in believing that nature is the realization of the mathematically simplest imaginable. By purely mathematical construction we can, in my opinion, find those concepts and the lawful connection between them that provide the key to understanding natural phenomena. The useful mathematical concepts can certainly be suggested by experience, but in no way derived from it. Experience remains, of course, the only criterion for the usefulness of a mathematical construction for physics. But the actual creative principle lies in mathematics. In a certain sense, I believe it is true that pure thought can grasp reality, as the ancients dreamed.

In order to justify this trust, I must necessarily use mathematical concepts. The physical world is represented by a four-dimensional continuum. If I assume a Riemannian metric in this and ask about the simplest laws that such a metric can satisfy, I arrive at the relativistic gravitational theory of empty space. If I assume a vector field in this space, or the antisymmetric tensor field derived from it, and ask about the simplest laws that such a field can satisfy, I arrive at Maxwell's equations of empty space.

Once we have reached this point, a theory for those parts of space in which the electrical density does not disappear is still missing. Louis de Broglie guessed the existence of a wave field that could be used to explain certain quantum properties of matter. Dirac found new field quantities in the spinors, the simplest equations of which allow us to derive the properties of the electron to a large extent. I then found with my colleague, Dr. Walter Mayer, that these spinors have a

They form a special case of a new type of field mathematically linked to the four-dimensional, which we called "semivectors". The simplest equations to which such semivectors can be subjected provide a key to understanding the existence of two types of elementary particles with different ponderable masses and the same but opposite charge. After ordinary vectors, these semivectors are the simplest mathematical field structures possible in a metric continuum of four dimensions, and it seems that they easily describe essential properties of elementary electrical particles.

What is essential for our consideration is that all these formations and their legal connections can be obtained according to the principle of searching for the mathematically simplest concepts and their connections. The theorist's hope of grasping reality in all its depth lies in the limitations of the mathematically existing simple field types and the simple equations that are possible between them.

The most difficult point for such a field theory is to understand the atomistic structure of matter and energy. The theory is not atomistic in its foundations in that it operates exclusively with continuous functions of space, in contrast to classical mechanics, whose most important element, the material point, already does justice to the atomistic structure of matter. Modern quantum theory in the form characterized by the names de Broglie, Schrödinger, Dirac, which operates with continuous functions, has overcome this difficulty through a bold interpretation that was first given in clear form by Max Born: the spatial functions appearing in the equations do not claim to be a mathematical model of the atomistic structures. These functions are only intended to determine mathematically the probabilities of finding such structures in the case of a measurement at a certain location or in a certain state of motion. This conception is logically sound and has achieved significant success. Unfortunately, it forces us to use a continuum whose number of dimensions is not that of the space of previous physics (namely four), but increases indefinitely with the number of particles constituting the system under consideration. I cannot help but confess that I attach only a temporary importance to this interpretation. I still believe in the possibility of a model of reality, i.e. a theory that represents things themselves and not just the probability of their occurrence.

On the other hand, it seems certain to me that we have to give up the idea of a complete localization of particles in a theoretical model. This seems to me to be the permanent result of the Heisenberg uncertainty principle. However, an atomistic theory in the true sense (not just on the basis of an interpretation) can very well be thought of without localization of particles in the mathematical model. In order to do justice to the atomistic character of electricity, for example, the field equations only need to lead to the following consequence. A three-dimensional part of space, at the boundary of which the electrical density disappears everywhere, always contains a total electrical charge of an integer magnitude. In a continuum theory, the atomistic character of the integral theorems could therefore be expressed satisfactorily without localization of the entities that make up the atomistic structure.

Only when such a representation of the atomistic structure has been achieved would I consider the quantum puzzle to be solved.

So far from the book: Albert Einstein, *My World View*, Ullstein Books No. 65, edited by Carl Seelig, pages 113-119. –

A cosmos that is no longer understood in its form and function, i.e. in its reality and thus in its effect and purpose, leads to disorientation and this in turn can be recognized by the fruits it produces.

This disorientation causes the loss of knowledge about what is true, good and beautiful and leads to ethical decline.

Thus, the other cultures and major religions outside the Christian cultural and religious sphere are stunned and shocked by the moral decline of the Western culture shaped by Christianity. For as technology conquered life in the Western cultures, the ethics of the rulers and peoples there sank. What once began as the liberation of humanity from slavery, the right of self-determination of people in the political form of democracy, mostly degenerated into a sophisticated system of defrauding voters and led to unbearable slavery by the tax authorities of those states that emphasize human freedom so much in their basic rights. Never before has humanity been taxed and exploited more heavily, except in an earlier system of physical and mental slavery.

What is still authority in functioning Christianity is oriented upwards, towards the DIVINE center, i.e. towards the reality created by the Creator God. The other "authority", i.e. the one that has power over people without this ethic, is oriented towards the advantage of its organization, be it a secret society or political parties that systematically eliminate the right of self-determination and thus the sovereignty of free people.

There is only one way out of this situation: recognizing reality and reconnecting with God's commandments and the associated human dignity and resulting duties and human rights.

SOURCES

About the pictures and the professors

U.G. Morrow, 1897; Book: "Cellular Cosmogony" p.95 description of the Rectilineter

Helmut I. Diehl  
Petristrasse 36  
71364 Winnenden  
Tel.: (07195) 920342